

This copy is a reprint which includes current pages from changes 1 through 3.

TM 5-4320-272-12

DEPARTMENT OF THE ARMY TECHNICAL MANUAL

TECHNICAL MANUAL

OPERATION AND ORGANIZATIONAL

MAINTENANCE MANUAL

**PUMPING ASSEMBLY, FLAMMABLE LIQUID,
BULK TRANSFER, GASOLINE ENGINE DRIVEN,
350 GPM CAPACITY, 275 FEET TOTAL
DYNAMIC HEAD,
WHEEL MOUNTED (PEABODY BARNES, INC.
MODEL US37ACG)**

FSN 4320-195-4914

HEADQUARTERS, DEPARTMENT OF THE ARMY

JANUARY 1974

WARNING

POISONOUS GASES

are contained in the exhaust fumes expelled by this equipment.

DEATH

or serious illness may result if exhaust fumes are not properly expelled from enclosed areas.

FLAMMABLE GAS

is generated in the battery of this equipment while the battery is being charged. Keep fire or flame away while servicing battery or explosion may result.

FIRE HAZARD

is created by filling fuel tank while engine is running. Shut off engine before servicing fuel tank.

EXPLOSION HAZARD

exists when welding repairs are attempted on fuel tank.

DEATH

may result unless all gasoline fumes are purged from tank before making any repairs involving heat or flame.

Changes in Force: C1, C2, C3, and C4

TM 5-4320-272-12

C 4

CHANGE

HEADQUARTERS

NO. 4

DEPARTMENT OF THE ARMY

WASHINGTON, D. C., 10 October 1990

Operator and Organizational Maintenance Manual

PUMPING ASSEMBLY, FLAMMABLE LIQUID BULK TRANSFER,
GASOLINE-ENGINE DRIVEN; 350 GPM CAPACITY, 275 FEET TOTAL
DYNAMIC HEAD; WHEEL MOUNTED (PEABODY BARNES, INC. MODEL US37ACG)
FSN 4320-00-195-4914

Approved for public release; distribution is unlimited

TM 5-4320-272-12, dated 14 January 1974, is changed as follows:

Page 2-5, paragraph 2-7(e) change to be paragraph (f).

Add new paragraph (e)

e. Increase battery PMCS. Use distilled water or a good grade drinking water (excluding mineral water).

Page 3-2, Table 3-1, Item 4, add note following warning and

Page 3-4, Table 3-2, Item 1, step 2, add note following warning

NOTE

Use distilled water or a good grade drinking water (excluding mineral water).

Page 4-1, paragraph 4-1(b) (1), add note

NOTE

Use an electrolyte with a specific gravity of 1.280. Do not use tropical electrolyte, which will reduce battery reserve capacity.

Page 4-16, paragraph 4-23 a (1), add note

NOTE

Use distilled water or a good grade drinking water (excluding mineral water).

Add Appendix C, Expendable/Durable Supplies and Materials List, immediately following page B-5.

APPENDIX A

EXPENDABLE/DURABLE SUPPLIES AND MATERIALS LIST

Section I. INTRODUCTION

C-1. SCOPE. This appendix lists expendable supplies and materials you will need to operate and maintain the Pumping Assembly, Flammable Liquid, GED, 350 GPM. This listing is for informational purposes only and is not authority to requisition the listed items. These items are authorized to you by CTA 50-970, Expendable/Durable Items (except Medical, Class V, Repair Parts, and Heraldic Items), or CTA 8-100, Army Medical Department Expendable/Durable Items.

C-2. EXPLANATION OF COLUMNS

a. Column (1)-Item number. This number is assigned to the entry in the listing and is referenced in the narrative instructions to identify the material (e.g., "Use cleaning compound, item 5. App. C").

b. Column (2)-Level. This column identifies the lowest level of maintenance that requires the listed item.

(enter as applicable)

- C - Operator/Crew
- O - Unit Maintenance
- F - Direct Support Maintenance
- H - General Support Maintenance

c. Column (3)-National Stock Number. This is the national stock number assigned to the item; use it to request or requisition the item.

d. Column (4)-Description. Indicates the Federal item name and, if required, a description to identify the item. The last line for each item indicates the Commercial and Government Entity Code (CAGEC) in parentheses followed by the part number.

e. Column (5)-Unit of Measure (U/M). Indicates the measure used in performing the actual maintenance function. This measure is expressed by a two-character alphabetical abbreviation (e.g., ea., in., pr). If the unit of measure differs from the unit of issue, requisition the lowest unit of issue that will satisfy your requirements.

SECTION II. EXPENDABLE/DURABLE SUPPLIES AND MATERIALS LIST

(1) ITEM NUMBER	(2) MAINT LEVEL	(3) NATIONAL STOCK NUMBER	(4) DESCRIPTION	(5) U/M
1	O	2805-00-374-3127	Electrolyte, (66289)	GL

TM 5-4320-272-12

C4

By Order of the Secretary of the Army:

CARL E. VUONO
General, United States Army
Chief of Staff

Official:

THOMAS F. SIKORA
Brigadier General, United States Army
The Adjutant General

DISTRIBUTION:

To be distributed in accordance with DA Form 12-25E, (qty rqr block no. 1342)

✦ U.S. GOVERNMENT PRINTING OFFICE: 1990 554-123/20032

CHANGE }
No. 3 }

HEADQUARTERS
DEPARTMENT OF THE ARMY
WASHINGTON, D.C., 4 February 1985

Operator and Organizational Maintenance Manual
PUMPING ASSEMBLY, FLAMMABLE LIQUID BULK TRANSFER;
GASOLINE-ENGINE DRIVEN; 350 GPM, 275 FEET TOTAL
DYNAMIC HEAD; WHEEL MOUNTED (PEABODY BARNES, INC.
MODEL US37ACG) NSN 4320-00-195-4914

TM 5-4320-272-12, 14 January 1974, is changed as follows:

Page 1-1, paragraph 1-2. All references to TM 38-750 is changed to read "DA Pam 738-750."

Page 1-1, paragraph 1-3. Reporting of Errors, line 6, change "ATTN: AMSTS-MPP, 4300 Goodfellow Boulevard, St. Louis, Missouri 63120" to read "ATTN: AMSTR-MPS, 4300 Goodfellow Blvd., St. Louis, MO. 63120-1798."

Page 3-2. Table 3-1 is superseded by Table 3-1.

Page 4-3. Table 4-1 is superseded by Table 4-1.

By Order of the Secretary of the Army:

JOHN A. WICKHAM, JR.
General, United States Army
Chief of Staff

Official:

DONALD J. DELANDRO
Brigadier General, United States Army
The Adjutant General

DISTRIBUTION:

To be distributed in accordance with DA Form 12-25A Operator and Organizational Maintenance requirements for Petroleum Distribution.

Table 3-1. Operator/Crew Preventive Maintenance Checks and Services

NOTE

Within designated interval, these checks are to be performed in the order listed.

B-Before

D-During

A-After

Item No.	Interval			Item to be Inspected	Procedures Check for and have repaired or adjusted as necessary	Equipment is Not Ready/ Available if:
	B	D	A			
1	●			Pump Assembly	<p>NOTE</p> <p>Perform lubrication prior to or in conjunction with before PMCS. Refer to LO 5-4320-272-12. Keep the engine and pump free of dirt and oil on all external surfaces.</p> <p>Make the following walk around checks:</p> <p>a. Inspect engine and pump for evidence of leakage (oil or fuel) on, around, or under the unit.</p> <p>b. Check for loose, damaged, or missing hardware and parts. Check that tires are inflated.</p> <p>c. Check air cleaner restriction indicator and dump vacuator valve. If indicator shows RED, remove filter element and service. (Para 3-9).</p> <p>d. Visually inspect fire extinguisher for full charge and proper working condition. Check ground rod assembly for corroded or broken clamps.</p>	<p>Class III oil leaks or any fuel leakage found.</p> <p>Missing engine shrouding.</p> <p>Indicator shows RED.</p> <p>Extinguisher not fully charged or in working condition. Assembly corroded or broken.</p>

Table 3-1. Operator/Crew Preventive Maintenance Checks and Services (cont)

Item No.	B-Before			Item to be Inspected	D-During	A-After
	Interval					
	B	D	A		Procedures Check for and have repaired or adjusted as necessary	Equipment is Not Ready/ Available if:
					NOTE	
2		●		Control Panel	During starting and operation check for unusual noise, rough running, lack of power, excessive smoke, and loss of output. Check for oil, fuel, and exhaust leaks. Check for any indication of a failing or defective component.	Oil pressure below 4 psi.
3			●	Fuel Tank	<u>WARNING</u> Do not fill fuel tank when engine is running or hot. Fill fuel tank.	

Table 4-1. Organizational Preventive Maintenance Checks and Services

Q-Quarterly

Item No.	Interval Q	Item to be Inspected	Procedures
1	●	Air Cleaner	<p>Check condition of air cleaner element. Clean or replace element and replace any other damaged parts. (para 4-17)</p> <p style="text-align: center;"><u>WARNING</u></p> <p>Do not smoke or use an open flame in the vicinity when servicing the battery. Batteries generate hydrogen gas, which is highly explosive.</p>
2	●	Battery	<p>Check level of electrolyte. If low, fill with clean water (distilled if possible) to the split ring. In freezing weather, charge battery at least 1 hour after adding water.</p>
3	●	Tires	<p>Inspect tires for proper inflation and condition. Repair or replace tires and tubes as necessary.</p>

CHANGE }
No. 2 }

HEADQUARTERS
DEPARTMENT OF THE ARMY
WASHINGTON, D.C., 21 November 1980

**Operator and Organizational Maintenance Manual
PUMPING ASSEMBLY, FLAMMABLE LIQUID, BULK TRANSFER;
GASOLINE-ENGINE DRIVEN; 350 GPM, 275 FEET TOTAL
DYNAMIC HEAD; WHEEL MOUNTED (PEABODY BARNES, INC.
MODEL US37ACG) NSN 4320-00-195-4914**

TM 5-4320-272-12, 14 January 1974, is changed as follows:

Page 2-4. Immediately following subparagraph 2-3a., add the following Warning:

WARNING

After removing the priming cap and filling the pump casing with the product to be pumped, check the snap-in gasket in the cap to be sure that it is present and that it is serviceable (No dents; cuts, abrasions). Remove and replace as necessary.

When the casing has been filled, place the cap on the male quick disconnect adapter and raise the cam levers on the cap to the fully locked (vertical) position.

Bind the cap cam levers together in the locked position with soft wire or heavy twine in order to eliminate any possibility of their release due to vibration. This procedure must be followed each time the pumping assembly is primed.

Page 3-5. Immediately following the Corrective Action of Malfunction No. 1, add the following Warning:

WARNING

After removing the priming cap and filling the pump casing with the product to be pumped, check the snap-in gasket in the cap to be sure that it is present and that it is serviceable (No dents; cuts, abrasions). Remove and replace as necessary.

When the casing has been filled, place the cap on the male quick disconnect adapter and raise the cam levers on the cap to the fully locked (vertical) position.

Bind the cap cam levers together in the locked position with soft wire or heavy twine in order to eliminate any possibility of their release due to vibration. This procedure must be followed each time the pumping assembly is primed.

Page 4-1. Immediately following subparagraph 4-2i., add the following Warning:

WARNING

After removing the priming cap and filling the pump casing with the product to be pumped, check the snap-in gasket in the cap to be sure that it is present and that it is serviceable (No dents; cuts, abrasions). Remove and replace as necessary.

When the casing has been filled, place the cap on the male quick disconnect adapter and raise the cam levers on the cap to the fully locked (vertical) position.

Bind the cap cam levers together in the locked position with soft wire or heavy twine in order to eliminate any possibility of their release due to vibration. This procedure must be followed each time the pumping assembly is primed.

TM 5-4320-272-12

By Order of the Secretary of the Army:

E. C. MEYER
General, United States Army
Chief of Staff

Official:

J. C. PENNINGTON
Major General, United States Army
The Adjutant General

DISTRIBUTION:

To be distributed in accordance with DA Form 12-25A Operator Maintenance requirements for Petroleum Distribution.

Change }
No. 1 }

HEADQUARTERS
DEPARTMENT OF THE ARMY
Washington, D. C. 15 July 1974

**Operator and Organizational Maintenance Manual
PUMPING ASSEMBLY, FLAMMABLE LIQUID BULK TRANSFER;
GASOLINE-ENGINE DRIVEN; 350 GPM, 270 FEET TOTAL
DYNAMIC HEAD; WHEEL MOUNTED (PEABODY BARNES, INC.
MODEL US37ACG) FSN 4320-195-4914**

TM 5-4320-272-12, 14 January 1974, is changed as follows:

Reverse of cover, add to warning:

NOISE HAZARD

Noise level exceeds allowable limits for unprotected personnel. Wear ear muffs or ear plugs which were fitted by a trained professional.

DANGEROUS CHEMICAL

Cleaning solvent, PD-680, is POTENTIALLY DANGEROUS CHEMICAL. Do not use near open flame.
Page 2-4, paragraph 2-4, add:

WARNING

Operation of this equipment presents a NOISE HAZARD to personnel in the area. Wear ear muffs or ear plugs which were fitted by a trained professional.

Page 3-1, paragraph 3-1, add:

WARNING

Dry cleaning solvent, PD-680, used for cleaning, is POTENTIALLY DANGEROUS CHEMICAL. Do not use near open flame. Flash point of solvent is 100F - 188F.

Page 4-2, paragraph 4-2k is added:

h. Signs conforming to provisions of AR 385-30 will be erected in the area to provide notification of NOISE HAZARD in accordance with TB MED-251. The signs should read:

WARNING

NOISE HAZARD EQUIPMENT HEARING PROTECTION REQUIRED

Paragraph 4-3g, add:

CAUTION

When towing pumping assembly do not exceed:

- a. 20 MPH over hard surfaced roads.
- b. 10 MPH over gravel surfaced roads.
- c. 8 MPH over rough cross-country terrain.
- d. 10 MPH over 1-inch obstructions, spaced at 5-6 feet intervals.
- e. 20 percent side slopes, or approach or depart a 30 percent ramp.
- f. 30 inches depth of water in fording operations.

Paragraph 4-8, add:

WARNING

Dry cleaning solvent, PD-680, used for cleaning is POTENTIALLY DANGEROUS CHEMICAL. Do not use near open flame. Flash point of solvent is 100F - 188F.

By Order of the Secretary of the Army:

Official:

VERNE L. BOWERS

Major General, United States Army

The Adjutant General

CREIGHTON W. ABRAMS
General, United States Army
Chief of Staff

Distribution:

To be distributed in accordance with DA Form 13-25A (qty req block No. 153) operator maintenance requirements for Petroleum Distribution.

Table 3-1. Operator/Crew Preventive Maintenance Checks and Services (cont)

Item No.	B-Before			Item to be Inspected	D-During	A-After
	Interval					
	B	D	A		Procedures Check for and have repaired or adjusted as necessary	Equipment is Not Ready/ Available if:
					NOTE	
2		●		Control Panel	During starting and operation check for unusual noise, rough running, lack of power, excessive smoke, and loss of output. Check for oil, fuel, and exhaust leaks. Check for any indication of a failing or defective component.	
3			●	Fuel Tank	Monitor gages for normal indications.	Oil pressure below 4 psi.
					<u>WARNING</u>	
					Do not fill fuel tank when engine is running or hot.	
					Fill fuel tank.	

Table 4-1. Organizational Preventive Maintenance Checks and Services

Q-Quarterly

Item No.	Interval Q	Item to be Inspected	Procedures
1	●	Air Cleaner	<p>Check condition of air cleaner element. Clean or replace element and replace any other damaged parts. (para 4-17)</p> <p style="text-align: center;"><u>WARNING</u></p> <p>Do not smoke or use an open flame in the vicinity when servicing the battery. Batteries generate hydrogen gas, which is highly explosive.</p>
2	●	Battery	<p>Check level of electrolyte. If low, fill with clean water (distilled if possible) to the split ring. In freezing weather, charge battery at least 1 hour after adding water.</p>
3	●	Tires	<p>Inspect tires for proper inflation and condition. Repair or replace tires and tubes as necessary.</p>

TECHNICAL MANUAL }
 No. 5-4320-272-12 }

HEADQUARTERS,
 DEPARTMENT OF THE ARMY
 WASHINGTON, D.C., 14 January 1974

OPERATION AND ORGANIZATIONAL MAINTENANCE MANUAL
PUMPING ASSEMBLY, FLAMMABLE LIQUID,
BULK TRANSFER, GASOLINE ENGINE DRIVEN,
350 GPM CAPACITY, 275 FEET TOTAL DYNAMIC HEAD,
WHEEL MOUNTED (PEABODY BARNES, INC. MODEL US37ACG)
FSN 4320-195-4914

		Paragraph	Page
CHAPTER	1. INTRODUCTION		
Section	I. General	1-1	1-1
	II. Description and data	1-7	1-1
CHAPTER	2. OPERATING INSTRUCTIONS		
Section	I. Operating procedures	2-1	2-1
	II. Operation under unusual conditions	2-6	2-5
CHAPTER	3. OPERATOR / CREW MAINTENANCE INSTRUCTIONS		
Section	I. Lubrication instructions	3-1	3-1
	II. Preventive maintenance checks and services	3-4	3-2
	III. Troubleshooting	3-6	3-3
	IV. Maintenance procedures	3-8	3-5
CHAPTER	4. ORGANIZATIONAL MAINTENANCE INSTRUCTIONS		
Section	I. Service upon receipt of materiel	4-1	4-1
	II. Movement to a new worksite	4-3	4-2
	III. Repair parts, special tools, and equipment	4-5	4-2
	IV. Lubrication instructions	4-8	4-2
	V. Preventive maintenance checks and services (monthly and quarterly)	4-10	4-2
	VI. Troubleshooting	4-12	4-4
	VII. Maintenance of exhaust system	4-14	4-6
	VIII. Maintenance of fuel system	4-16	4-6
	IX. Maintenance of electrical system	4-22	4-15
	X. Maintenance of non-electrical gages	4-29	4-27
	XI. Maintenance of engine	4-32	4-28
	XII. Maintenance of wheels	4-35	4-29
	XIII. Maintenance of accessory items	4-38	4-31
	XIV. Maintenance of pump	4-40	4-33
APPENDIX	A. REFERENCES		A-1
	B. MAINTENANCE ALLOCATION CHART		B-1
	C. BASIC ISSUE ITEM LIST AND ITEMS TROOP INSTALLED OR AUTHORIZED (Not Applicable)		
INDEX		I-1

LIST OF ILLUSTRATIONS

<i>Number</i>	<i>Title</i>	<i>Page</i>
1-1	Pumping assembly, right three-quarter front view	1-2
1-2	Pumping assembly, left three-quarter front view	1-3
1-3	Wiring diagram	1-5
2-1	Control panel controls and instruments.	2-1
2-2	Right side view of pump showing controls	2-2
2-3	Fuel primer	2-3
3-1	Engine lubrication	3-1
3-2	Oil filter replacement.	3-6
3-3	Air cleaner installation	3-6
3-4	Air cleaner, exploded view.	3-7
3-5	Fuel strainer, exploded view.	3-8
3-6	Suction strainer, exploded view.	3-9
4-1	Muffler and piping, exploded view	4-6
4-2	Air cleaner and piping, exploded view	4-8
4-3	Fuel tank, lines, and fittings, exploded view	4-10
4-4	Fuel pump and fuel strainer, exploded view	4-12
4-5	Carburetor adjustments	4-13
4-6	Governor and carburetor linkage.	4-13
4-7	Manifold and carburetor, exploded view	4-14
4-8	Battery box and battery, exploded view	4-17
4-9	Ignition system, exploded view.	4-20
4-10	Magneto timing	4-22
4-11	Magneto-to-spark plug connections	4-23
4-12	Starting motor and brush replacement, exploded view	4-24
4-13	Control panel and instruments, exploded view	4-26
4-14	Wheel assembly, exploded view	4-30
4-15	Accessory items, exploded view,	4-32
4-16	Suction piping assembly, exploded view	4-34
4-17	Discharge piping assembly, exploded view	4-36
4-18	Gate valve, exploded view	4-37
4-19	Check valve, exploded view.	4-38
4-20	Air eliminator, exploded view.	4-39

CHAPTER 1

INTRODUCTION

Section I. GENERAL

1-1. Scope

This manual is for your use while operating and maintaining Pumping Assembly, Flammable Liquid, Bulk Transfer, Gasoline Engine Driven, 350 GPM Capacity, 275 Feet Total Dynamic Head, Wheel Mounted (Peabody Barnes, Inc. Model US37ACG). You are instructed to perform the maintenance allocated by the Maintenance Allocation Chart.

1-2. Maintenance Forms and Records

Maintenance forms and records that you are required to use are explained in TM 38-750.

1-3. Reporting of Errors

You can improve this manual by calling attention to errors and by recommending improvements, using DA Form 2028 (Recommended Changes to

Publications), or by a letter, and mail directly to Commander, U.S. Army Troop Support Command, ATTN: AMSTS-MPP, 4300 Goodfellow Boulevard, St. Louis, Missouri 63120. A reply will be furnished directly to you.

1-4. Equipment Serviceability Criteria

This equipment is not covered by an ESC.

1-5. Destruction of Army Materiel to Prevent Enemy Use

For instructions regarding destruction of equipment to prevent enemy use, refer to TM 750-244-3.

1-6. Administrative Storage

You must prepare the pumping assembly for storage according to the procedures given in TM 740-90-1.

Section II. DESCRIPTION AND DATA

1-7. Description

a. Model US37ACG Two-Wheel Mounted Pumping Assembly consists primarily of a gasoline engine, centrifugal pump, and welded frame. The

pump is coupled directly to the engine and the pump impeller is mounted on the engine crankshaft.

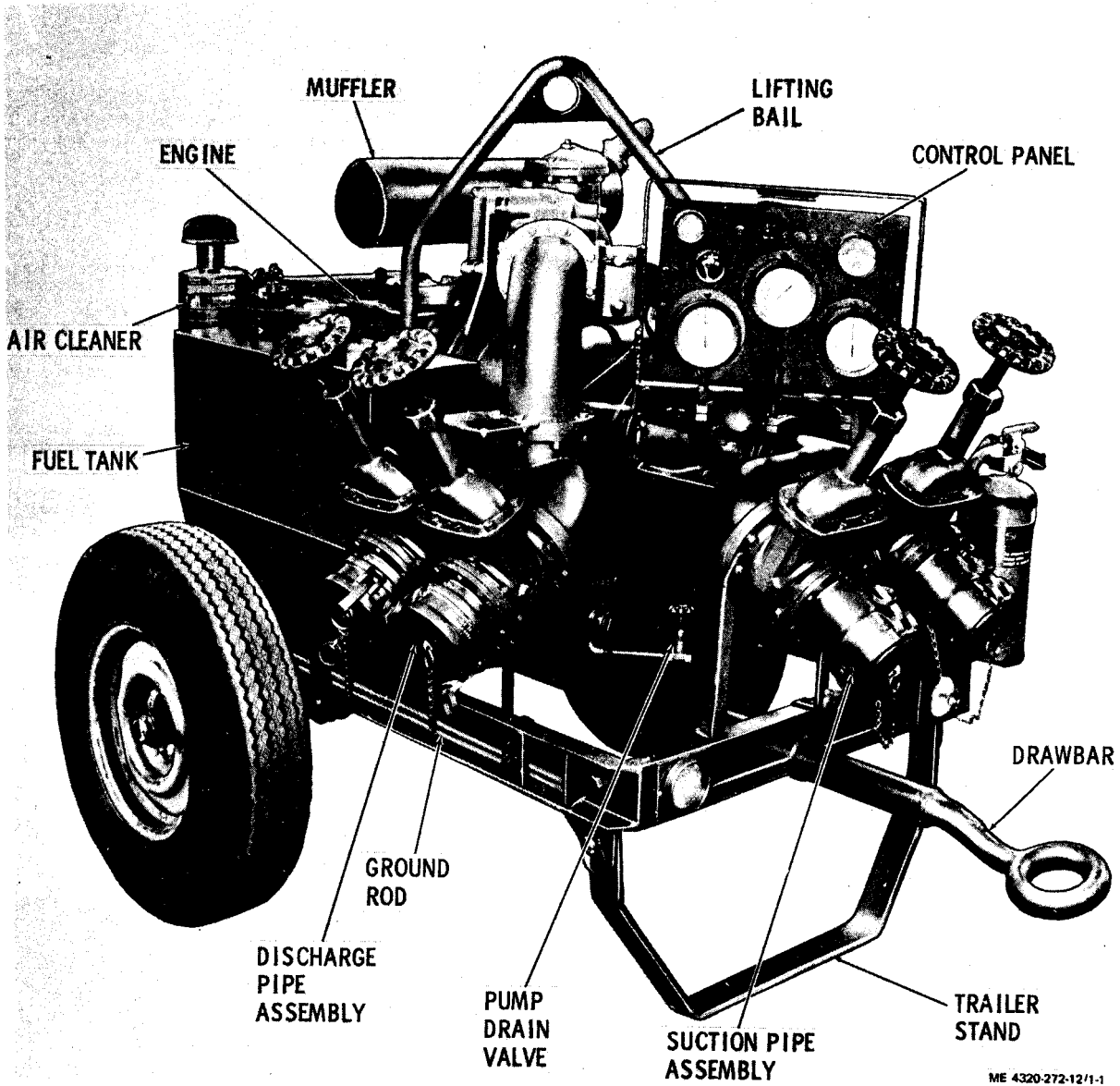
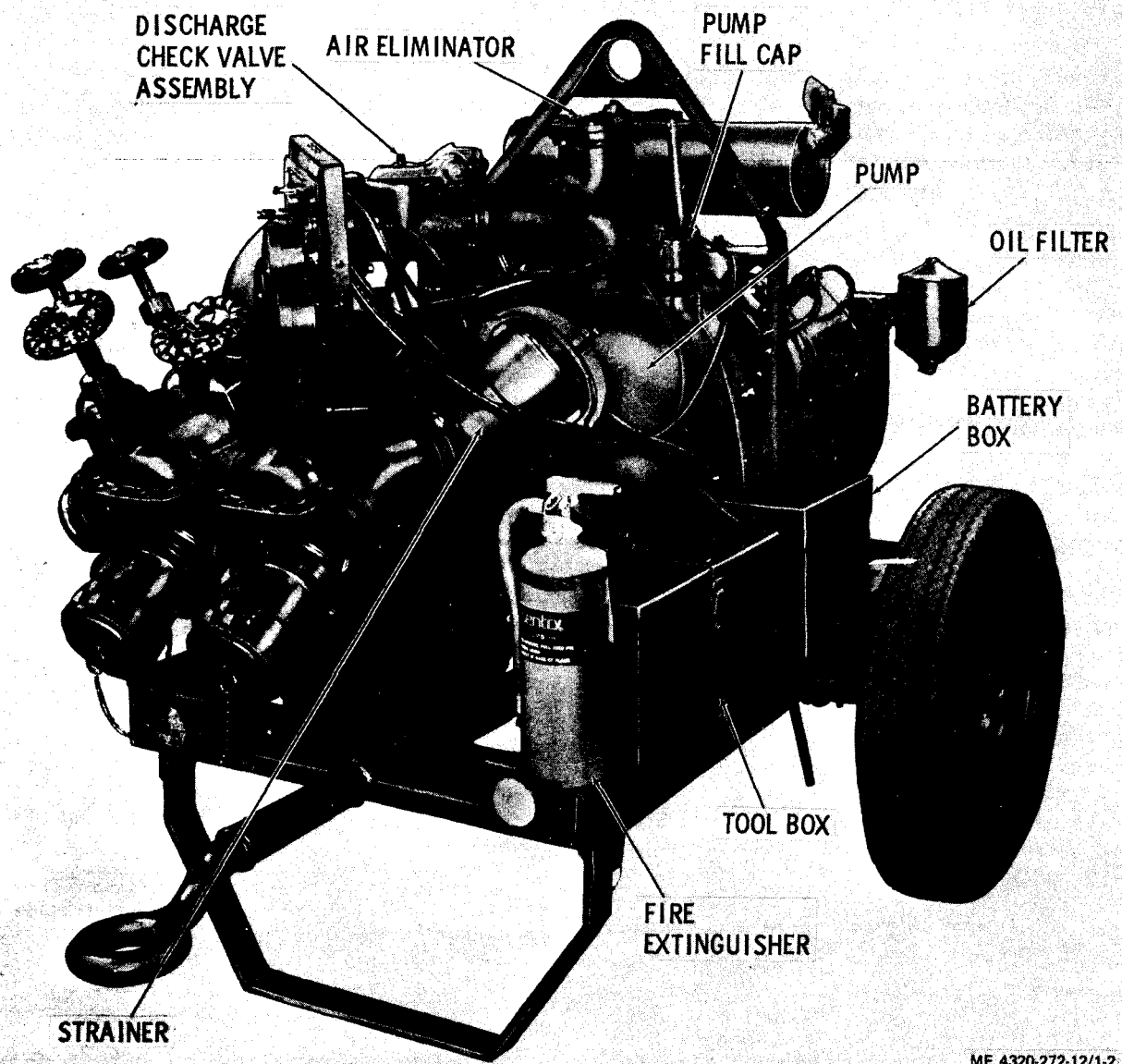

Figure 1-1. Pumping assembly, right three-quarter front view.



ME 4320-272-12/1-2

Figure 1-2. Pumping assembly, left three-quarter front view.

b. A 4 inch suction pipe assembly consisting primarily of a strainer, manifold, and two gate valves, is secured to the front of the pump body. A 4 inch discharge pipe assembly, consisting primarily of air eliminator, check valve, manifold, and two gate valves, is secured to the top of the pump body. The coupling joins the engine crankcase with the pump body, providing correct spacing and proper alinement of the parts. The impeller is threaded onto the engine crankshaft and held secure by the opposing rotation of the engine. The impeller is enclosed in a close-fitting volute to provide efficient pumping operation. Replaceable wear plates at the front and rear of the impeller take most of the internal pump wear.

c. The engine is a V-type, four-cylinder, air-cooled, pressure-lubricated, four-stroke-cycle unit with an L-head. Engine speed is controlled by the inter-operation of a governor and carburetor. The engine is cooled by a flow of air, circulated over the heads by a combination fan-flywheel enclosed in a sheet metal shroud. The engine uses an electrical starting motor, has magneto ignition, and uses a flywheel alternator to maintain the charge of the battery.

d. The engine and pump are secured to a two-wheeled welded frame. The frame weldment consists primarily of a drawbar, fixed axle, hub assemblies, and pneumatic tires.

e. The maintenance paragraphs of this manual

contain detailed descriptions of centrifugal pump components.

1-8. Differences in Models

This publication covers only Pumping Assembly, Peabody Barnes, Inc. Model US37ACG. No. known differences exist among the units bearing this model number.

1-9. Tabulated Data

a. Identification. The pumping assembly has the following four identification plates for your reference:

(1) *Pump data plate.* The pump data plate is located on a bracket mounted on the discharge piping. It indicates the pump identification number, serial number, dimensions, weight, and shipping information.

(2) *Pump performance plate.* The pump perform ante plate is located on the inside of the tool box cover. It indicates the pump capacities and performances.

(3) *Engine data plate.* The engine data plate is located on top of the flywheel shroud. It indicates the engine identification numbers, oil and gasoline specifications, operating and maintenance instructions.

(4) *Military data plate.* The military data plate is located on the engine flywheel shroud. It indicates the military specification number and issue number.

b. Tabulated Data. Tabulated data applicable to the pumping assembly and its components is given in table 1-1.

Table 1-1. Tabulated Data

Manufacturer	Peabody Barnes, Inc.
Model number	US37ACG
Specification	52549
Serial number range	.52549-001 and up
Type	Self-priming, centrifugal
Pumping medium	Flammable liquids
Output (at maximum rated speed)	.350 gpm
Total dynamic head	.275 feet
Rated driven speed	2350 rpm
Suction port resize.	4 in.
Discharge port size	4 in.
Engine	
Manufacturer	Teledyne Wisconsin Motor
Model	MVG4D
Specification	361739
Type	Four stroke cycle
Number of cylinders	4
Displacement	148 .5 cu in.

Table 1-1. Tabulated Data - Continued

Cooling	Air
Crankcase oil capacity (including oil filter)	.6 qt
Oil pressure switch cutout	1 psi
Valve clearance (cold)	
Intake	.008 in.
Exhaust	.016 in.
Spark plug gap	.030 in.
Breaker point gap	.015 in.
Firing order	1-3-4-2
Governed speed	
Full load	2350 rpm
Alternator	
Manufacturer	Wisconsin
Type	Flywheel mounted
Voltage	24
Amperage output	12
Starting motor	
Manufacturer	Prestolite
Part number	MBP-4018T
Voltage	24
Magento	
Manufacturer	Fairbanks-Morse
Part number	FM-XZE4B7
Fuel strainer	
Manufacturer	Tillotson
Part number	OW-444
Carburetor	
Manufacturer	Wisconsin
Part number	L57-2S1
Air cleaner	
Manufacturer	Donaldson
Part number	FWA05-2527
Oil filter	
Manufacturer	Fram
Part number	F21-P
Hourmeter-tachometer	
Manufacturer	Stewart-Warner
Part number	567AAC 2350 rpm
Gate valve	
Manufacturer	OPW
Part No.	676
Size	.4 in.
Air eliminator	
Manufacturer	Peabody Barnes, Inc.
Part number	.37458SA
Overall dimensions and weight	
Overall length	
Extended	.109½ in.
Retracted	.68½ in.
Overall width	.57½ in.
Overall height	62 in.
Overall weight	1320 lbs
Shipping weight	1470 lbs
Shipping volume	.162 cu ft
Torque specifications	
Spark plugs	.25 to 30 ft-lb

c. Wiring Diagram. Refer to figure 1-3.

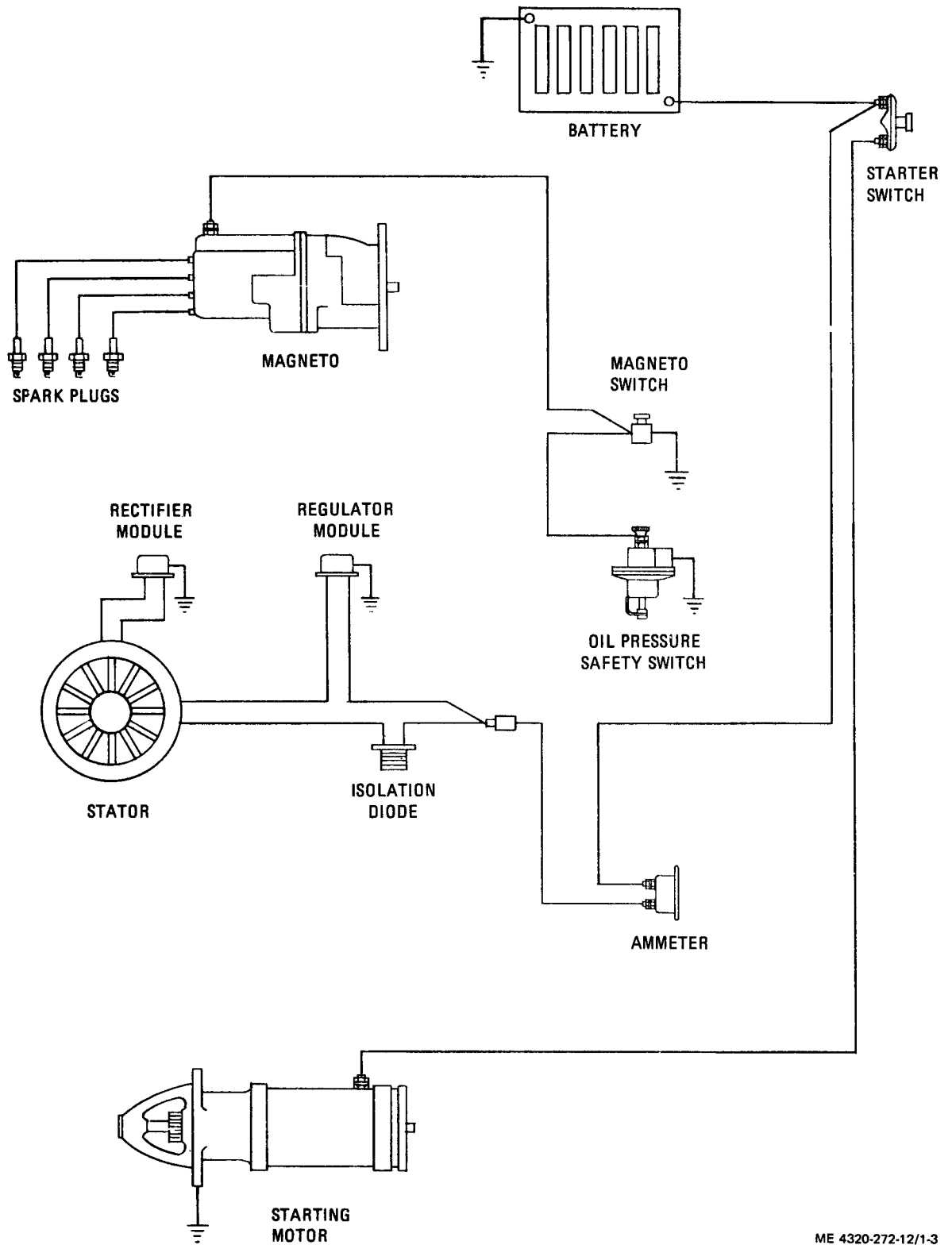

ME 4320-272-12/1-3

Figure 1-3. Wiring diagram.

CHAPTER 2

OPERATING INSTRUCTIONS

Section I. OPERATING PROCEDURES

2-1. General

This section contains information and guidance for the personnel responsible for operation of the pumping assembly. This section gives instructions on starting and stopping the pump and basic operations of the unit.

2-2. Controls and Instruments

Before attempting to operate the pumping

assembly, you must become familiar with all controls and instruments provided on the unit. Refer to table 2-1 for a complete description and identification of all controls and instruments used on the pumping assembly. The controls and instruments are illustrated in figures 2-1 through 2-3.

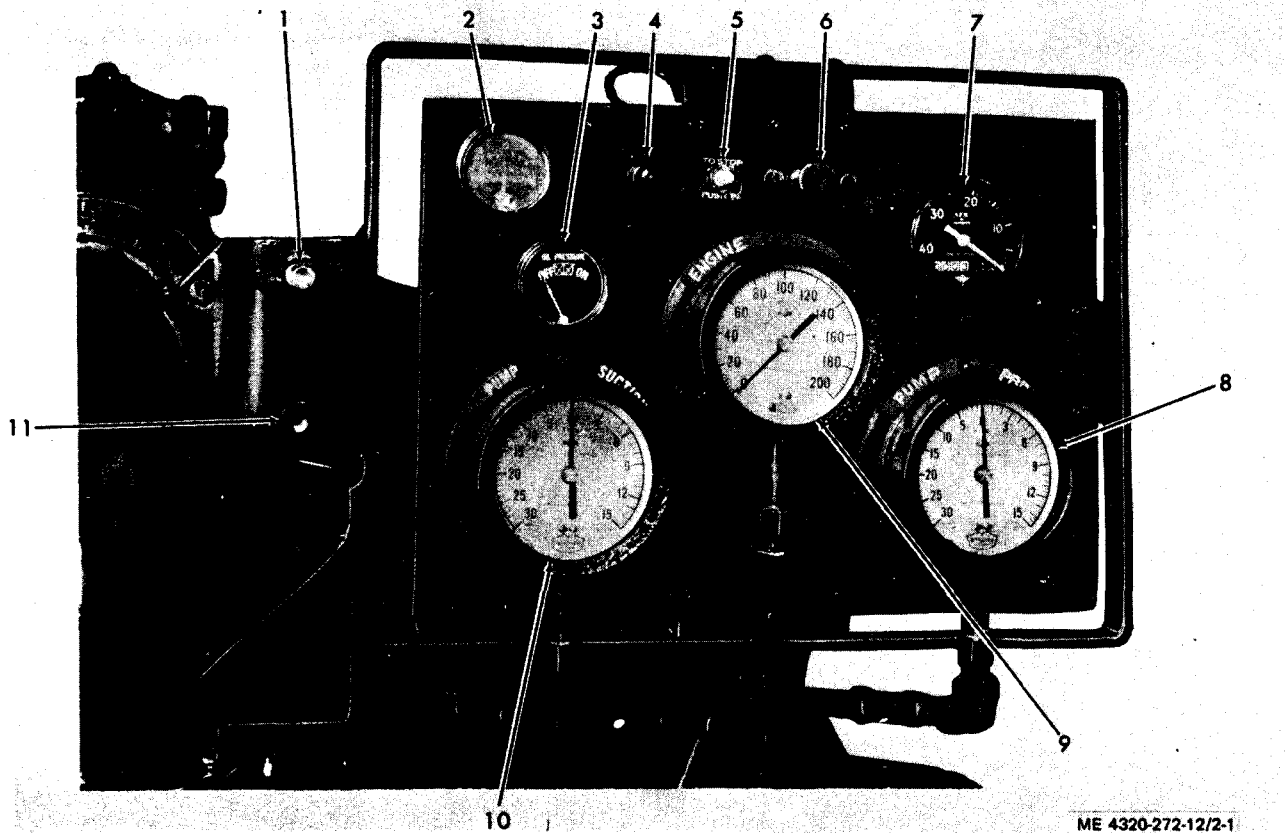

- | | |
|---------------------------------------|---------------------------------|
| 1. Throttle control | 7. Engine tachometer-hourmeter |
| 2. Ammeter | 8. Pump discharge pressure gage |
| 3. Oil pressure gage | 9. Engine vacuum gage |
| 4. Oil pressure safety switch plunger | 10. Pump suction gage |
| 5. Magneto switch | 11. Engine choke control |
| 6. Starter switch | |

Figure 2-1. Control panel controls and instruments.

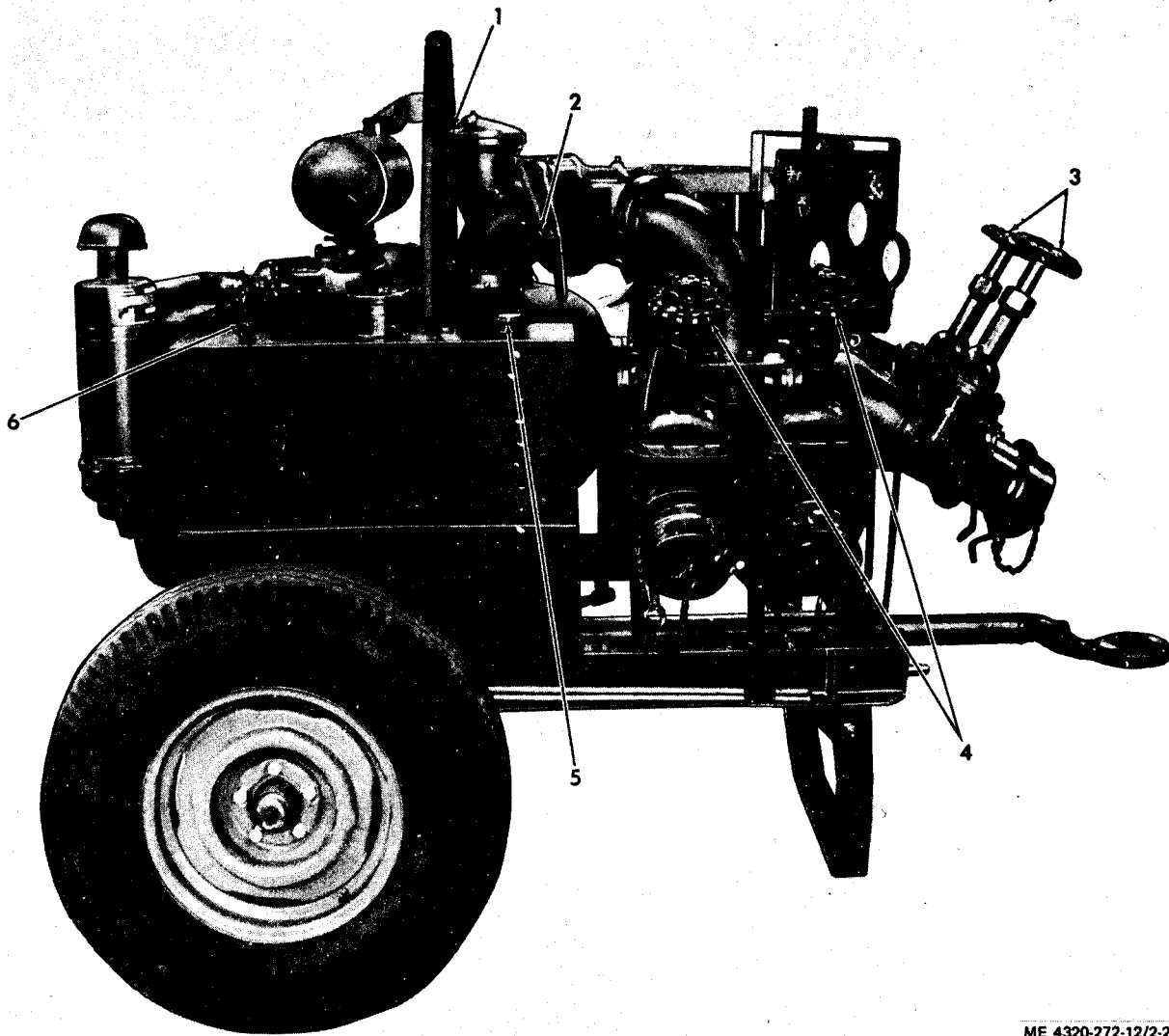

ME 4320-272-12/2-2

- | | |
|--------------------------------|-------------------------------|
| 1. Air eliminator vent valve | 4. Discharge valve |
| 2. Check valve override handle | 5. Fuel gage |
| 3. Suction valve | 6. Fuel source selector valve |

Figure 2-2. Right side view of pump showing controls.

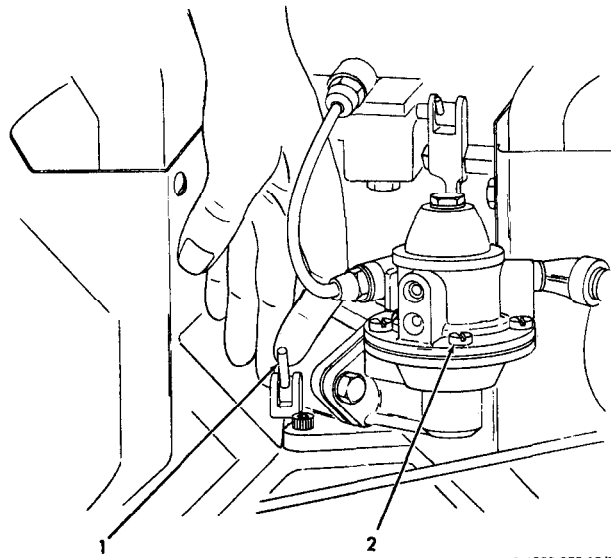

ME 4320-272-12/2-3

1. Hand primer lever

2. Fuel pump

Figure 2-3. Fuel primer.

Table 2-1. Controls and Instruments

Fig. No.	Index No.	Description
2-1	1	THROTTLE CONTROL. Controls engine speed to adjust it to discharge pressure requirements. When you pull out control, it increases engine speed. When you push in control, it decreases engine speed. Engine speed governor controls engine maximum speed.
2-1	2	AMMETER. Indicates if the battery is being charged or discharged while the engine is running. Ammeter should show high charge rate to restore battery immediately after starting and then taper off to near zero with continued operation.
2-1	3	OIL PRESSURE GAGE. Indicates engine oil pressure. At normal operating temperature, oil pressure must be 4 to 5 psi. Gage may indicate higher when oil is cold.
2-1	4	OIL PRESSURE SAFETY SWITCH PLUNGER. Prevents the oil pressure safety switch from grounding the magneto during starting. When you start the engine, the plunger shaft must be pulled out and the spring clip is inserted under the recess in the housing. Spring kicks out when engine pressure reaches safe operating level. You must reset each time engine is started.
2-1	5	MAGNETO SWITCH. When pressed while the engine is running, it grounds the magneto to stop engine operation.
2-1	6	STARTER SWITCH. When pressed and held, it causes the starter to crank the engine for starting.
2-1	7	ENGINE TACHOMETER-HOURMETER. Indicates engine speed in rpm and indicates in hours and tenths of hours the amount of time the engine has run. The latter provides information for your pump maintenance scheduling.
2-1	8	PUMP DISCHARGE PRESSURE GAGE. Indicates pump discharge pressure at the pump outlet in pounds per square inch. Optimum readings depend upon pump applications.
2-1	9	ENGINE VACUUM GAGE. Indicates in inches of mercury the vacuum level of the engine intake manifold. This provides you with an indication of engine load. Should show no less than 5 inches during normal operation.
2-1	10	PUMP SUCTION GAGE. Indicates either suction or pressure at pump inlet, depending upon pump application.
2-1	11	ENGINE CHOKE CONTROL. Provides a control of the engine choke to facilitate your choke adjustment for starting and running.
2-2	1	AIR ELIMINATOR VENT VALVE. Permits air and fluid to be expelled through the drain hose during priming cycle. Vent valve is normally left open during operation.
2-2	2	CHECK VALVE OVERRIDE HANDLE. When you operate the handle counterclockwise while the pump is stopped, it raises the valve from the seat and allows the fluid from the discharge to drain back through the pump and suction valves back to the fluid source to drain the discharge lines when the discharge is higher than the inlet. You can adjust it to remain in open position if required.

Table 2-1. Controls and Instruments-Continued

Fig. No.	No.	Description
2-2	3	SUCTION VALVES. Controls fluid source entering the pump. You turn valve handles counterclockwise to open valves.
2-2	4	DISCHARGE VALVES. Provide control of fluid discharge from pump. You turn valve handles counterclockwise to open valves.
2-2	5	FUEL GAGE. Indicates the level of fuel in the fuel tank.
2-2	6	FUEL SOURCE SELECTOR VALVE. Controls the source of fuel to the engine. In the OFF position it shuts off the fuel source. In the TANK position it connects the engine fuel system to the fuel supply in the fuel tank. In the AUX position it connects the engine fuel system to an auxiliary external fuel supply, if connected.
2-3	1	HAND PRIMER LEVER. When operated back and forth, it pumps fuel to prime the fuel lines at initial starting or after the engine has been idle for an extended period of time.

2-3. Starting

Start the pumping assembly as follows:

CAUTION

Make sure you prime the pump before attempting to start it. Starting a dry pump may damage the shaft seal making seal replacement necessary.

a. Close the suction valves. Check that the drain valve at the bottom of the pump housing is closed. Remove the priming fill cap (fig. 1-2) and fill the pump housing to the level of the plug with the fluid to be pumped.

b. Open the air eliminator vent valve (1, fig. 2-2).

c. If the engine is being started for the first time, or if the unit has been standing idle for a considerable length of time, you will need to prime the fuel system, filling the fuel lines and the carburetor float bowl. Use the hand primer lever (1, fig. 2-3). When priming, a distinct resistance to movement of the hand primer must be felt. If you do not feel this resistance, turn the engine crankshaft one revolution so that the fuel pump lobe on the camshaft is rotated out of engagement with the fuel pump cam follower to permit movement of the fuel pump diaphragm with the lever. Hand prime for about 20 or 30 strokes. You will feel less resistance to hand primer lever movement when the fuel bowl is filled.

d. Pull out the throttle control (1, fig. 2-1) half way.

e. Pull out the choke control (11) all the way.

f. Pull out on the oil pressure safety switch plunger (4) and engage the spring clip into the recessed underside of the housing to hold the switch contacts open for starting. You must reset this switch each time you start the pump.

g. Press and hold the starter switch (6). The starting motor should crank the engine. After several revolutions of the crankshaft, push in the choke control (11) half way.

h. The engine should start after a few

revolutions of the crankshaft. If it does not, do not continue to crank with the starter. You should use short, intermittent starting cycles. Excessive cranking will cause the starting motor to overheat and may damage it. However, more cranking is normally necessary in cold weather than in warm.

i. After the engine starts, push in the choke control as necessary to provide smooth engine operation. When the engine is warmed up, you must push in the choke all the way.

j. Run the engine at high idle speed for a few minutes to allow it to warm up before applying the pump load.

2-4. Operation

After starting, operate the pumping assembly as follows:

a. Open the applicable suction valve (3, fig. 2-2) to provide fluid from the required source.

b. Open the discharge valve (4) to direct the fluid to the required destination.

c. Operate the throttle control (1, fig. 2-1) to increase engine speed so that the tachometer indicates approximately 1000 rpm. Pump should pick up prime within a few minutes. Fluid flow from the pump is indicated by movement of the check valve override handle (2, fig. 2-2) as the check valve is pushed from its seat.

d. If prime is not made within a few minutes, you can increase engine speed to 1500 rpm until prime is achieved, then reduce speed immediately to 1000 rpm. This will reduce shock in the discharge lines as they fill up with fluid.

e. Watch the pump discharge pressure gage and regulate the discharge valve(s) to maintain the required flow.

f. Increase engine speed as required. During operation, maintain an indication of at least 5 inches on the engine vacuum gage (9, fig. 2-1). An indication of less than 5 inches means that the pump engine is overloaded. You can control the pump load by regulating the discharge valves.

g. It is essential that you periodically check the engine oil pressure gage and ammeter during operation to assure that they remain within their required ranges.

h. You can put the pump in standby condition by closing the discharge valves. However, extended pump operation with both valves tightly closed will cause the fluid in the volute to heat up and possibly boil. To avoid this you can leave one of the discharge valves cracked open slightly to maintain a continuous flow of fluid through the pump. If this is not possible, shut off the pump to prevent long non-pumping intervals from causing excessive heating of the fluid being pumped.

2-5. Stopping

CAUTION

Do not stop the engine by pulling out

Section II. OPERATION UNDER UNUSUAL CONDITIONS

2-6. Operation in Extreme Cold

a. You must keep the pump free of ice and snow at all times. Cover it when not in use and, if possible, provide some shelter from the weather.

b. Refer to LO 5-4320-272-12 to assure that the engine lubricant is the proper grade for the coldest conditions likely to be encountered.

c. Keep the fuel tank filled when the pump is not in use. By doing this you will prevent moisture from condensing in the fuel system. Moisture in the fuel system can freeze and clog lines, filters, and carburetor jets, preventing fuel from reaching the engine.

d. Service the fuel filter frequently to remove any moisture which may have collected in the fuel bowl.

2-7. Operation in Extreme Heat

a. You should protect the pump assembly from direct rays of the sun if possible.

b. Allow adequate space for ventilation. If the pump is operated in an enclosure, you can use a fan to circulate the air.

c. Keep the engine and shrouding clean to provide proper heat transfer to the air.

d. Check that the lubricants used in the engine comply with LO 5-4320-272-12.

e. Although you can stop fluid flow for short periods, you are advised not to do so in extreme heat for the fluid may boil in the volute.

2-8. Operation in High Altitudes

The operating efficiency of both engine and pump

the choke. This floods the cylinders with raw gasoline, which washes away the lubricants and makes the engine susceptible to wear.

To stop the engine, you press and hold the magneto switch (5, fig. 2-1) until the engine stops. If the engine had been running hard and is hot, do not stop it abruptly. Instead, you should reduce the load by operating the throttle lever to reduce speed and shut off the suction valves to remove the load. Allow the engine to run for 3 to 5 minutes before shutting off. This will allow internal engine temperatures to decrease, minimizing the danger of valve warpage and other internal engine damage.

diminishes at higher altitudes. Make sure that the engine is operating at peak efficiency, providing you with the highest possible pump output.

2-9. Operation in Sandy or Dusty Areas

a. The frequency of air cleaner service must be increased when you are operating the pumping assembly under conditions of extreme sand or dust.

b. While filling the fuel tank, take care to prevent sand and dust from entering the fuel system. Watch the fuel strainer bowl for accumulations of dirt.

2-10. Operation Under Rainy, or Humid Conditions

a. Take care to prevent moisture from entering the fuel system. You should fill the fuel tank immediately after every operating period to prevent moisture in the air from condensing and entering the fuel system. Maintain a careful check of the fuel strainer bowl for collection of moisture.

b. Take special care to prevent rust and corrosion of exposed metal surfaces.

2-11. Operation in Salt Water Areas

a. Because of the corrosive action of salt water, use fresh water to wash off any salt water that comes in contact with the equipment. This will help you prevent the formation of rust and corrosion.

b. Take special care to prevent rust and corrosion of exposed metal surfaces.

CHAPTER 3

OPERATOR/CREW MAINTENANCE INSTRUCTIONS

Section I. LUBRICATION INSTRUCTIONS

3-1. General

This section contains supplemental information and lubrication instructions that the operator must perform on the pumping assembly. Lubrication Order LO 5-4320-272-12 will indicate to you the required lubrication points, intervals, and detailed instructions.

3-2. Detailed Lubrication Information

a. Keep all lubricants in closed containers and store in a clean, dry place away from external heat. Allow no dust, dirt, or other foreign material to mix with the lubricants. Keep all lubrication equipment clean and ready to use.

b. Keep all external parts not requiring lubrication free of lubricants. Before lubricating the equipment, wipe all lubrication points free of dirt and grease. Clean all lubrication points after you lubricate them to prevent accumulation of dirt.

c. You must take the following precautions when using a subzero engine oil:

(1) The crankcase oil level must be checked frequently, as oil consumption may increase.

(2) The oil may require changing more frequently than usual because contamination by fuel dilution and sludge formation will increase under cold weather operation conditions.

d. Service the oil filter as described in paragraph 3-8 b.

3-3. Engine Lubrication

Engine crankcase lubrication consists primarily of changing the oil in the crankcase and servicing the oil filter (LO 5-4320-272-12). Proceed as follows:

a. Run the engine long enough to heat it to operating temperature. This is important since warm oil will drain from the internal engine parts much more rapidly than cold oil. The warm oil will also carry more dirt and sludge with it as it drains.

b. Place suitable containers under the engine drain port before you remove the oil pan drain plug (3, fig. 3-1). Allow the oil to drain fully.

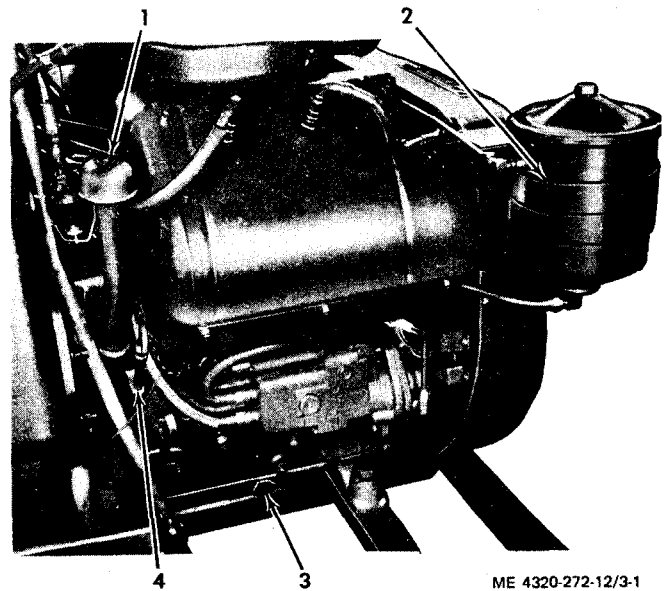

ME 4320-272-12/3-1

1. Oil filler cap
2. Oil filter
3. Oil drain plug
4. Dipstick

Figure 3-1. Engine lubrication.

c. If engine is operated under extreme dusty conditions, you should replace the filter element at every oil change. Refer to paragraph 3-8 b for oil filter replacement instructions.

d. Install the plug in the drain port.

e. Remove the oil filler cap (1, fig. 3-1) from the engine oil filler pipe and pour 6 quarts of engine oil into the engine. You must use the engine oil required for the particular temperature range which will be encountered. Refer to LO 5-4320-272-12.

f. Check the oil level on the oil level dipstick (4,

fig. 3-1). It must be up to the full mark. If you find the oil level to be low, add enough oil through

the oil filler pipe to bring the oil up to the proper level. Take care not to overfill.

Section II. PREVENTIVE MAINTENANCE CHECKS AND SERVICES

3-4. General

To insure that the pumping assembly is ready for operation at all times, you must inspect it systematically so that defects may be discovered and corrected before they result in serious damage or failure. The necessary preventive maintenance services to be performed by you are listed in table 3-1. The sequence numbers indicate the order in which you should perform the preventive maintenance checks and services. Defects discovered during operation of the unit shall be noted for correction, to be made as soon as operation has ceased. Stop operation immediately if a deficiency

is noted during operation which would damage the equipment if operation were continued. You shall record all deficiencies and shortcomings together with the corrective action taken on DA Form 2404 (Equipment Inspection and Maintenance Worksheet). Correct all deficiencies at the earliest possible opportunity.

3-5. Preventive Maintenance Checks and Services

Refer to table 3-1 for a listing of operator / crew preventive maintenance checks and services.

Table 3-1. Operator / Crew Preventive Maintenance Checks and Services

D-Daily

W-Weekly

Interval and sequenc no.		Item to be inspected procedure
D	W	
1		ENGINE OIL Before operation, check oil level in crankcase. Add oil if necessary (para 3-8 a).
2		AIR CLEANER Dump vacuator valve. Empty the dust cup. Check for dirty filter element (para 3-9 a).
3		FUEL SYSTEM WARNING Do not fill fuel tank while engine is running. Fill tank if necessary. Check for secure mountings. Check for fuel leaks (para 3-9 b).
4		BATTERY WARNING Do not smoke or use an open flame in the vicinity when servicing the battery. Batteries generate hydrogen gas, which is highly explosive. Check fluid level. If low, fill to the proper level with distilled water (para 3-10).
5		EXHAUST SYSTEM Check muffler, pipes, and manifold for damage and leaks. Report damage to organizational maintenance.
6		GENERAL Before operation, check for loose or missing bolts, screws, nuts, loose or disconnected hoses and fittings, binding or seizing of rotating parts, and other damage. Report damage to organizational maintenance.
7		UNUSUAL OPERATION During operation, check for leaking, low pumping rate, excessive vibration, overheating or other abnormal operation. Report trouble to organizational maintenance.
8		UNUSUAL NOISES During operation, check for abnormal noises such as impeller rubbing or air sucking into intake. Report trouble to organizational maintenance.
	9	FUEL STRAINER Check for dirt or water in fuel bowl. Service if necessary (para 3-9 c).
	10	DUST PLUGS AND CAPS Check for broken retaining chains and missing dust caps and plugs which cover suction and discharge piping during storage and transfer. Report deficiencies to organizational maintenance.

Table 3-1. Operator/ Crew Preventive Maintenance Checks and Services-Continued

D-Daily		W-Weekly
Interval and sequence no.		Item to be inspected procedure
D	W	
	11	PUMP ASSEMBLY Check for cracks, loose or missing plugs, leaks, signs of overheating, and other damage. Report damage to organizational maintenance.
	12	GATE VALVES Check for difficult operation, leaks, and other damage. Report deficiencies to organizational maintenance.
	13	CONTROL PANEL Check for inoperative or illegible gages, defective switches, or damaged controls. Report deficiencies to organizational maintenance.
	14	ENGINE SHROUDING Check for damaged panels and parts. Report damage to organizational maintenance.
	15	SUCTION STRAINER WARNING Clean all parts in a well-ventilated area. Avoid inhalation of solvent fumes and prolonged exposure of the skin to cleaning solvent. Wash exposed skin thoroughly. Remove strainer basket and clean with solvent (fed. spec. P-D-680). Inspect basket for holes, dirt, and other damage. Inspect gaskets for damage. Inspect cover for loose mounting (para 3-12).
	16	GROUND ROD ASSEMBLY Inspect for broken or corroded clamps. Report deficiencies to organizational maintenance.
	17	TIRES Inspect for improper inflation, cuts, breaks, blisters, and flat spots. Inspect valve stems for leaks. Service if necessary (para 3-11).

Section III. TROUBLESHOOTING

3-6. General

a. This section contains troubleshooting information for locating and correcting most of the operating troubles which may develop in the pumping assembly. Each malfunction for an individual component, unit, or system is followed by a list of tests or inspections which will help you to determine probable causes and corrective actions to take. Perform the tests/inspections and corrective actions in the order listed.

b. This manual cannot list all malfunctions that may occur, nor all tests or inspections and

corrective actions. If you experience a malfunction which is not listed or is not corrected by listed corrective actions, notify your supervisor.

3-7. Operator / Crew Maintenance Troubleshooting

Refer to table 3-2 for troubleshooting which is allocated to operator/crew maintenance levels.

NOTE

Before you use this table, be sure you have performed all applicable operating checks.

Table 3-2. Troubleshooting

MALFUNCTION	TEST OR INSPECTION	CORRECTIVE ACTION
ENGINE		
1. ENGINE FAILS TO TURN OVER WHEN STARTING BUTTON IS DEPRESSED.		
	Step 1. Check to see if electrolyte level in battery cells is above the top of the plates.	
WARNING		
Do not smoke or use an open flame in the vicinity when servicing the battery. Batteries generate hydrogen gas, which is highly explosive.		
If electrolyte level is below top of plates, add distilled water until electrolyte level is ½ inch above separators. Recharge batteries.		
	Step 2. Inspect for loose, corroded, or broken battery cables.	Clean corroded cables. Tighten loose connections at battery, ground, and starter. If cables are broken, notify organizational maintenance.
2. ENGINE TURNS OVER BUT FAILS TO START.		
	Step 1. Check to be sure oil pressure safety switch was reset.	Reset oil pressure safety switch.
	Step 2. Check for insufficiently choked carburetor, especially when engine is cold.	Pull out choke.
	Step 3. Check for empty fuel tank.	
WARNING		
Do not fill fuel tank while engine is running.		
Refill empty fuel tank.		
	Step 4. Check for improper setting on fuel source valve.	Set fuel source selector valve on TANK or AUX as required.
	Step 5. Check for water or dirt in fuel filter bowl.	Drain fuel tank and lines. Refill with fresh fuel.
	Step 6. Operate hand primer lever on fuel pump.	Crank engine. Engine should start if trouble was due to empty fuel lines caused by extended period of idleness.
	Step 7. Check for inoperative fuel pump.	Disconnect fuel line at carburetor. Crank engine and check for fuel flow from line. If pump is not operating, notify organizational maintenance.
	Step 8. Check for flooded carburetor, especially if engine is hot.	Turn over engine with choke open (choke control handle pushed in) and throttle open (throttle control handle pulled out).
3. ENGINE STARTS BUT THEN STOPS.		
	Step 1. Check for insufficient fuel supply.	Refill empty fuel tank.
	Step 2. Check fuel filter bowl for contaminated fuel.	Drain fuel tank and lines. Refill with fresh fuel.
	Step 3. Check for pulled out choke.	Push in choke control.
	Step 4. Check for tripped oil pressure safety switch.	If switch has been tripped, check oil level. If low, fill to proper level with recommended oil (para 3-3). If oil level is not low, report the trouble to organizational maintenance.
	Step 5. Check for clogged fuel line (para 3-9 b).	Loosen slightly the fuel line nut at carburetor. If line is open, fuel should drip out at loosened nut. Report clogged fuel line to organizational maintenance.
4. ENGINE RUNS BUT CONTINUALLY MISFIRES.		
	Step 1. Check for water in fuel.	Drain fuel tank and lines. Refill with fresh fuel.
	Step 2. Check for clogged fuel strainer.	Service fuel strainer (para 3-9 c). Replace strainer element.
5. ENGINE OVERHEATS.		
	Step 1. Check oil level.	If oil level is low, fill to the proper level with recommended oil (para 3-3).
	Step 2. Check that all air shrouding is unclogged and in place and undamaged.	Remove foreign matter from air shrouding. Tighten loose shrouding. Notify organizational maintenance of other damage.
	Step 3. Check for broken vanes on flywheel.	If flywheel has broken vanes, notify organizational maintenance.

Table 3-2. Troubleshooting-Continued

MALFUNCTION	TEST OR INSPECTION	CORRECTIVE ACTION
ENGINE—Continued		
6. ENGINE RUNS BUT LACKS POWER.	Step 1. Check that throttle control is in full speed position.	If throttle control is not in full speed position, pull out throttle control to provide full speed operation.
	Step 2. Check for restriction in air cleaner.	If air cleaner is dirty, service in accordance with paragraph 3-9.
7. ENGINE KNOCKS.	Step 1. Check for overheated engine.	Correct causes of engine overheating as listed in malfunction 5.
	Step 2. Check for low oil level.	If oil level is low, fill to proper level with recommended oil. Refer to LO 5-4320-272-12.
8. ENGINE OPERATES ERRATICALLY	Step 1. Check for clogged fuel line.	Loosen slightly the fuel line nut at carburetor. If line is open, fuel should drip out at loosened nut. If line is clogged, notify organizational maintenance.
	Step 2. Check fuel filter bowl for water in fuel.	Drain fuel tank and lines. Refill with fresh fuel.
	Step 3. Check for loose ignition connections.	Tighten loose connections.
	Step 4. Check for leaks in air intake system.	Tighten screws and replace gaskets to correct leaks.
PUMP ASSEMBLY		
1. PUMP FAILS TO PRIME.	Step 1. Check for insufficient priming liquid in pump.	Prime pump (para 2-3 a).
	Step 2. Check for loose connection on suction side of pump.	Check gaskets in suction piping. Make sure unused suction gate valve is fully closed.
	Step 3. Check for excessive suction lift.	Reduce suction lift to below 10 feet static head.
	Step 4. Check for clogged suction strainer.	Service suction strainer (para 3-12).
	Step 5. Check for stuck or damaged check valve.	Free stuck check valve. If valve is damaged, notify organizational maintenance.
	Step 6. Check pump for air or vapor block.	Make sure the air vent discharge line is open.
2. PUMP FAILS TO DEVELOP HEAD.	Step 1. Check for leak in suction line.	If leaks are detected, notify organizational maintenance.
	Step 2. Check for low engine speed.	Operate throttle to increase engine speed.
	Step 3. Check for excessive suction lift.	Reduce suction lift to below 10 feet static head.
	Step 4. Check for clogged suction strainer.	Service suction strainer (para 3-12).

Section IV. MAINTENANCE PROCEDURES

3-8. Maintenance of Engine

Operator / crew maintenance of the engine consists primarily of the following procedures:

- a. *Changing Engine Oil.* You must change the oil at least every 50 hours of engine operation. Refer to paragraph 3-3 for oil changing procedures.
- b. *Replacing Oil Filter.* You should change the

oil filter every 100 hours, unless operating under extreme dust conditions. Under extreme conditions, replace oil filter at every oil change. To change filter, proceed as follows:

- (1) Use a wrench on the hex head screw on the cover (1, fig. 3-2) and remove the filter cover and gasket (2).

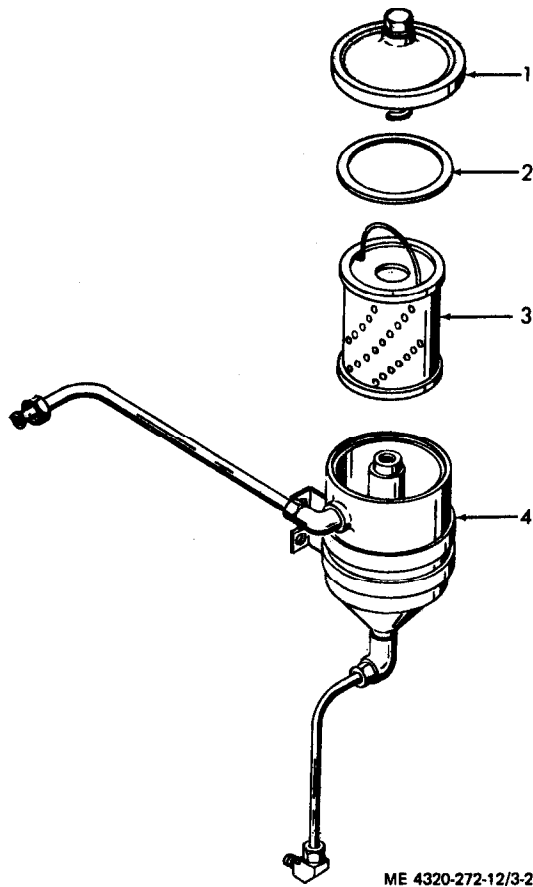

ME 4320-272-12/3-2

- 1. Cover
- 2. Gasket
- 3. Element
- 4. Body and lines

Figure 3-2. Oil filter replacement.

(2) You can now grasp the filter element (3) by its handle and lift it from the filter housing. Discard the filter element.

(3) Wipe the interior of the filter housing with a clean, dry cloth.

(4) Position a new filter element in the filter housing.

(5) Install the cover and gasket on the filter and tighten the hex screw at the top of the filter to secure the cover (1).

(6) After installing a new filter, check the oil level dipstick (4, fig. 3-1). It must be up to the full mark. Add oil if you find the level low, but do not overfill. Use oil recommended in paragraph 3-3.

3-9. Maintenance of Fuel System

Operator / crew maintenance of the fuel system consists primarily of the following procedures:

a. Servicing Air Cleaner.

(1) Daily, or several times a day under extremely dusty conditions, with the engine stopped,

open the lips of the vacuator valve (4, fig. 3-3) to release the collected dust. This will lengthen the life of the main filter.

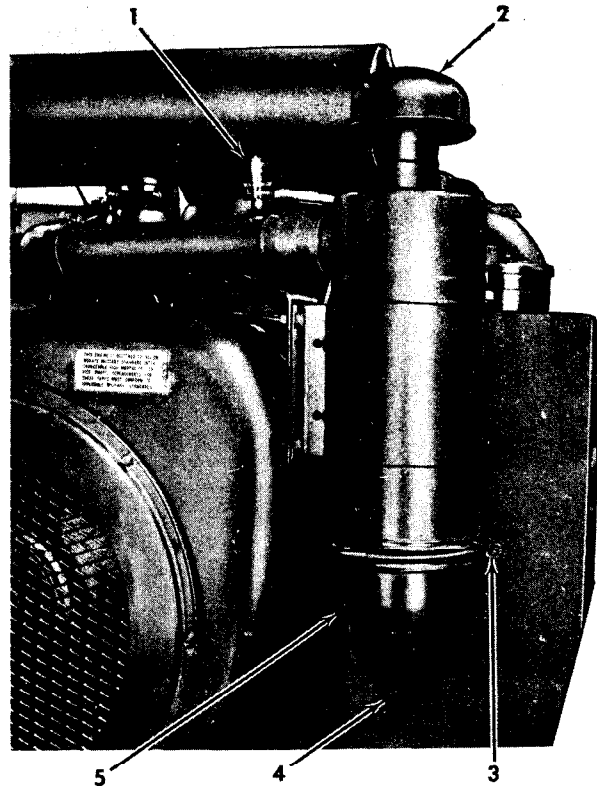

ME 4320-272-12/3-3

- 1. Air restriction indicator
- 2. Stack cap
- 3. Clamp
- 4. Vacuator valve
- 5. Dust Cup

Figure 3-3. Air cleaner installation.

(2) Daily, unless experience indicates that it can be done less frequently, loosen the clamp (3) and remove the dust cup. Remove the baffle from the cup and empty the dust. When reinstalling the baffle in the cup, you must make sure the baffle is properly seated. Check the dust cup sealing edge for damage. Check the dust cup gasket. Reinstall the dust cup and make sure it is properly positioned on the air cleaner body.

(3) Weekly, or any time the restriction indicator shows red in the sight area, service the air cleaner element. To remove the element, remove the cup and baffle as directed in step (2), above. Remove the wing nut (5, fig. 3-4) and remove the element (6). The element can be dry-cleaned with compressed air. Direct the air stream from the inside out. If you prefer, you can wash the air cleaner element with soap and water. Dry it with circulating air at less than 180°F. Replace element if any damage is visible. Reassemble the air cleaner.

CAUTION

Do not attempt to clean the air cleaner element with gasoline, kerosene, or solvent.

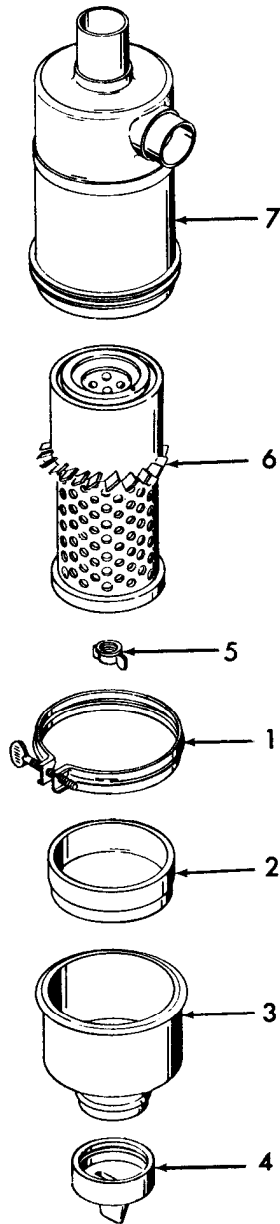

ME 4320-272-12/3-4

- | | |
|-------------------|----------------------|
| 1. Clamp assembly | 5. Wing nut assembly |
| 2. Baffle | 6. Element |
| 3. Dustcup | 7. Body |
| 4. Vacuator valve | |

Figure 3-4. Air cleaner, exploded view.

b. *Servicing Fuel Tank, Lines and Fittings.* Normal operation of the pump and engine requires no maintenance of the fuel tank, lines, and fittings other than that which is obvious such as filling tank with fuel and tightening loose fittings. When engine operation becomes faulty or erratic, you may need to perform one or all of the following:

WARNING

Clean all parts in a well-ventilated area. Avoid inhalation of solvent fumes and prolonged exposure of the skin to cleaning solvent. Wash exposed skin thoroughly.

(1) Drain and clean fuel tank. To drain contaminated fuel from tank, remove plug and drain fuel into suitable container. Flush out the fuel tank and fuel lines with solvent (fed. spec. P-D-680). You can clean the strainer with a soft-bristled brush to remove embedded material.

(2) Inspect the fuel tank and lines for leaks, cracks, dents, damaged threads, and broken weldments. Report any damage to organizational maintenance.

(3) Check for clogged fuel lines by loosening slightly the fuel line nut at carburetor. If the line is open, fuel will drip out at the loosened nut. If you find that the fuel line is clogged, report it to organizational maintenance.

c. *Servicing Fuel Strainer.* If you observe moisture or other contaminants through the glass bowl of the fuel strainer, service the strainer as follows :

(1) Operate the fuel source selector valve (6, fig. 2-2) to OFF.

(2) Loosen the nut on the bail (1, fig. 3-5) and swing the bail aside to release the glass fuel bowl (2). Empty the contents of the bowl and wipe it dry with a clean cloth.

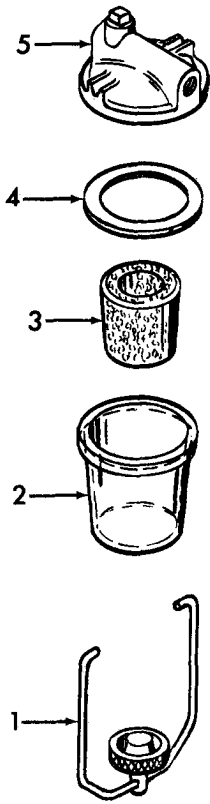

ME 4320-272-12/3-5

- | | |
|---------------------|--------------------------|
| 1. Bail | 4. Gasket |
| 2. Fuel bowl | 5. Fuel strainer housing |
| 3. Strainer element | |

Figure 3-5. Fuel strainer, exploded view.

(3) If the strainer element (3) is contaminated, replace it with a new one.

(4) Position the gasket (4) and fuel bowl (2) on the fuel strainer housing (5). Swing the bail (1) into position and tighten the bail nut to hold the bowl in place.

(5) After you have reinstalled the fuel strainer, open the fuel selector valve and check for leaks. Correct any leaks.

3-10. Maintenance of Electrical System

Operator/crew maintenance of the electrical system consists primarily of servicing the battery. Keep battery filled to the required level with distilled water. Keep the top of the battery and the battery terminals clean. To protect the terminals from corrosion, you can coat them with a light application of vaseline or GAA lubricant.

3-11. Maintenance of Wheels

Operator / crew maintenance of wheels consists primarily of servicing the tires, as follows:

- a. Clean tires and wheels with fresh, clean water.
- b. Remove foreign material embedded in the tires. If you remove nails or other penetrating objects, be sure to inspect for puncture of the tube.
- c. Inspect wheels and rims for damage. Inspect tires for cracks, deep cuts, or separated tread.
- d. Keep tires inflated to 60 psi.
- e. Report any defects or damage to organizational maintenance personnel.

3-12. Servicing Suction Strainer

Service the suction strainer as follows:

- a. Loosen the lock nut (2, fig. 3-6) on the set-screw (1) and loosen the setscrew to release the clamp (3). Now you can disengage the clamp from the housing and remove the cover (4) and gasket (5).

b. Remove the basket gaskets (6 and 8) and basket (7) from the housing.

c. You should thoroughly clean the basket with cleaning solvent (fed. spec. P-D-680) and a soft-bristled brush. Inspect the basket for holes and tears; replace if damaged.

d. Inspect all gaskets and replace any that are defective.

e. Reinstall all parts as shown in figure 3-6. Tighten the clamp using the setscrew (1). Be sure you then lock the setscrew by tightening the lock nut (2).

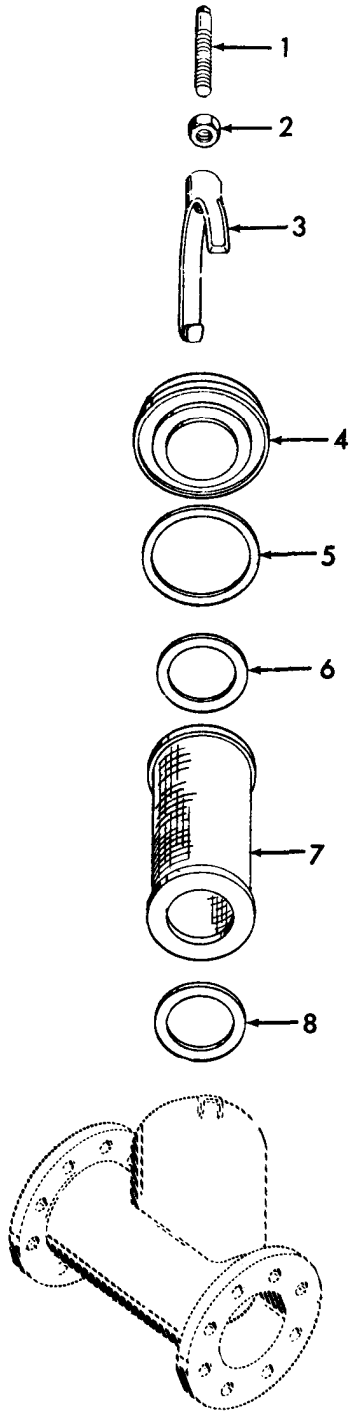

ME 4320-272-12/3-6

- 1. Setscrew
- 2. Nut
- 3. clamp
- 4. Cover

- 5. Gasket
- 6. Gasket
- 7. Basket
- 8. Gasket

Figure 3-6. Suction strainer, exploded view.

CHAPTER 4

ORGANIZATIONAL MAINTENANCE INSTRUCTIONS

Section I. SERVICE UPON RECEIPT OF MATERIEL

4-1. Inspecting and Servicing the Equipment.

a. Before you install the pumping assembly, inspect the equipment as follows:

(1) Inspect for cracks, dents, and other damage that may have occurred during shipment.

(2) Inspect for loose or missing hardware. Tighten all loose hardware.

(3) Check the engine for leaking.

(4) Inspect the suction and discharge piping for cracks, damaged valves, and other damage.

(5) Remove the tape from all engine and pump openings that have been sealed.

(6) Using the engine crank, turn over the engine. You should trip oil pressure switch to keep engine from starting. The engine and pump shall turn freely without binding or scraping or other signs of faulty operation.

(7) Inspect the control panel (fig. 1-1) for damaged controls and instruments.

(8) Report any damage to your supervisor.

b. Servicing the pump consists of the following procedures:

(1) If you are preparing the pumping assembly for initial use, open the container of electrolyte and fill the dry charge battery so that the electrolyte is up to the required level. If possible charge the battery for 10 or 15 minutes before connecting and applying the starting load. Refer to paragraph 4-23 for battery charging instructions. Make sure you have securely connected the battery. Note that the electrical system has a negative ground.

WARNING

Do not smoke or use an open flame in the vicinity when servicing the battery. Batteries generate hydrogen gas, which is highly explosive.

(2) Fill the fuel tank (fig. 1-1) with gasoline. Fuel tank capacity is 20 gallons.

4-2. Installation

a. Locate the pump assembly on a solid, flat surface as close to the source of fluid as practicable to minimize the suction lift. You should allow ample room around the pump to support the suction and discharge hoses and to service the pump as required. Before the pump is disengaged from the towing vehicle, pull down and pin the

trailer stand (fig. 1-1) to provide a rest for the pump. You can prevent the pump from moving during operation by blocking the wheels securely.

b. Using a 4 inch hose, connect the fluid source to one of the suction couplings of the suction pipe assembly. If the fluid is to be taken from alternate sources, connect the second source of supply to the second suction coupling.

c. Keep the suction line as short as possible and the suction lift as low as possible.

d. The suction line should be installed with as few bends as possible.

e. The highest point in the suction line should be at the pump, and the line should be laid in a decline from the pump to the source.

f. Make sure that your connections in the suction line are air-tight. Even a small leak will greatly reduce pumping efficiency and may cause difficulty in priming, especially when your pump is operating with a high suction lift.

g. Connect the discharge hose to one of the couplings of the discharge pipe assembly. If fluid is to be supplied to alternate locations, connect a discharge hose to the second discharge coupling.

h. Remove the ground rods (fig. 1-1) from the side of the pump trailer. Drive the ground rods into the ground adjacent to the pump. Connect the ground cable and clip assemblies between the pump and ground rod to assure good ground connections.

i. Close the suction valves. Check that the drain valve (fig. 1-1) at the bottom of the pump housing is closed. To prime the pump, remove the primer fill cap (fig. 1-2) and fill the pump housing to the level of the port with the fluid to be pumped.

j. If fuel for the engine is to be provided from an alternate, external source, connect the external line to the port on the fuel source selector valve (6, fig. 2-2) on the fuel tank. Operate the fuel valve to the AUX position.

WARNING

Do not operate the pumping unit in an enclosed area unless exhaust gases are piped to the outside. Inhalation of exhaust fumes will result in serious illness or death. If the pumping assembly is operated indoors, you must provide piping to carry exhaust gases to the outside of the building. Make sure

that the diameter of the exhaust piping is large enough to prevent excessive back pressure in the engine.

Section II. MOVEMENT TO A NEW WORKSITE

4-3. Dismantling for Movement

Dismantle the pumping assembly for movement to a new worksite as follows:

a. Disconnect the suction and discharge lines from the pump. If possible, drain the lines before disconnecting them from the pump. If you operate check valve override handle (2, fig. 2-2), it opens check valve and allows fluid to siphon from lines if source is lower than delivery point. Drain the lines into a suitable container.

6. Open the drain valve (fig. 1-1) at the bottom of the pump to drain the pump housing. Catch the fluid in a suitable container.

c. To keep debris from entering the pump suction and discharge piping, you must install dust plugs and caps on the couplings.

d. If you were operating the pump from an auxiliary fuel source, disconnect the fuel line from the 3-way fuel source valve (6, fig. 2-2) on the fuel tank.

e. Disconnect any exhaust piping from the pump.

f. Drain the engine as necessary.

g. Hitch the drawbar (fig. 1-1) to the towing vehicle. Make sure it is secured properly. If necessary, you can extend the drawbar to provide a greater turning clearance with the towing vehicle. Lift the trailer stand (fig. 1-1); using pins provided, secure it under trailer frame. Unblock the trailer wheels.

4-4. Reinstallation After Movement

Refer to paragraph 4-2 for installation instructions.

Section III. REPAIR PARTS, SPECIAL TOOLS, AND EQUIPMENT

4-5. Tools and Equipment

There are no tools, equipment, or repair parts issued with the pumping assembly,

4-6. Special Tools and Equipment

No special tools or equipment is required for organizational maintenance of the pumping assembly.

4-7. Maintenance Repair Parts

Repair parts and equipment are listed in the repair parts and special tools list covering organizational maintenance for this equipment. Refer to TM 5-4320-272-20P.

Section IV. LUBRICATION INSTRUCTIONS

4-8. General

This section contains supplemental information and lubrication instructions that must be followed for the pumping assembly at the organizational maintenance level. Refer to LO 5-4320-272-12 for your lubrication points, intervals, and detailed instructions. Also, reference to paragraphs 3-2 and

3-3 of this manual will provide you with additional lubrication information.

4-9. Trailer Lubrication

Lubrication at organizational maintenance consists primarily of lubricating trailer wheel bearings. Refer to paragraph 4-37 for wheel bearing maintenance and lubrication instructions.

Section V. PREVENTIVE MAINTENANCE CHECKS AND SERVICES (MONTHLY AND QUARTERLY)

4-10. General

This section lists the preventive maintenance checks and services which shall be performed on a monthly or quarterly basis by organizational

maintenance personnel. It includes and expands upon the preventive maintenance services performed by operator/ crew maintenance and includes additional services which are allocated to organizational maintenance.

4-11. Preventive Maintenance Checks and Services

maintenance checks and services which are allocated to organizational maintenance.

Refer to table 4-1 for a listing of the preventive

Table 4-1. Organizational Preventive Maintenance Checks and Services

M—Monthly		Q—Quarterly
Interval and sequence no.		
M	Q	Item to be inspected procedure
1		ENGINE OIL Check that engine oil and filter have been changed at required interval.
2		AIR CLEANER Check condition of air cleaner element. Clean or replace element and replace any other damaged parts. Refer to paragraph 4-17.
3		FUEL SYSTEM Correct any leaks and replace defective parts. Check fuel for contamination. Refer to paragraph 4-18.
4		BATTERY
		WARNING
		Do not smoke or use an open flame in the vicinity when servicing the battery. Batteries generate hydrogen gas, which is highly explosive.
		Test battery condition with a hydrometer. Replace battery if it fails to take and maintain a charge. Refer to paragraph 4-23.
5		EXHAUST SYSTEM Clean and check exhaust system for damage and leaks. Replace muffler or any other parts of exhaust system if damaged or if leaks are noticed. Refer to paragraph 4-15.
6		FUEL STRAINER Check for dirt or water in fuel bowl. Service if necessary (para 3-9c). Replace fuel strainer if clogged. Refer to paragraph 4-19.
7		ENGINE SHROUDING Check for loose, missing, or damaged engine shrouding. Repair or replace shrouding as necessary.
8		CONTROL PANEL Inspect for inoperative or illegible gages, defective switches, or damaged controls. Replace as required. Refer to paragraph 4-28.
9		DUST PLUGS AND CAPS Check for missing dust plugs or caps. Replace if necessary.
10		SUCTION AND DISCHARGE PIPING Check for leaks, cracks, or damage. Repair or replace as necessary any damaged or leaking suction or discharge piping parts. Refer to paragraphs 4-41 and 4-42.
11		GATE VALVES Check all gate valves by operating them. Repair or replace valves which leak, are difficult to operate, or are otherwise damaged. Refer to paragraph 4-43.
12		SUCTION STRAINER Check condition of suction strainer. Clean if necessary. Replace damaged strainer and gaskets. Refer to paragraph 3-12.
13		GROUND ROD ASSEMBLY Inspect the ground rod and related parts. Clean corrosion from clamps and other parts. Replace any damaged parts.
14		TIRES Inspect tires for proper inflation and condition. Repair or replace tires and tubes as necessary. Refer to paragraph 4-36.
15		CARBURETOR Make a visual inspection of carburetor. Check operation of throttle lever and choke lever. Adjust as necessary. Replace a damaged carburetor. Refer to paragraph 4-20.
16		FUEL PUMP Check fuel pump for leaks or damage. Replace fuel pump if defective. Refer to paragraph 4-19.
17		GOVERNOR AND CONTROLS Check governor operation and inspect for damage. Adjust the governor if full load speed is not between 2300 and 2350 rpm. Refer to paragraph 4-21.
18		BATTERY CHARGING SYSTEM Check ammeter with engine running. After initially high charging rate, rate should slowly reduce to near zero. Notify direct and general support maintenance of faulty operation.

**Table 4-1. Organizational Preventive Maintenance
Checks and Services-Continued**

Interval and sequence no.		Item to be inspected procedure
M	Q	
19		STARTING MOTOR Clean and check starting motor operation. Inspect brushes and replace if worn. Replace damaged starting motor. Refer to paragraph 4-27.
20		SPARK PLUGS Check for cleanliness and proper gap. Clean and regap if necessary. Replace defective plugs. Refer to paragraph 4-26.
21		MAGNETO Check breaker point opening. It must be .015 inch. Replace burned points and adjust point gap. Refer to paragraph 4-25.
22		OIL PRESSURE SWITCH Clean and check for damage. Make sure switch spring clip disengages at engine startup and that switch trips at engine shutdown. Replace faulty switch. Refer to paragraph 4-28.
23		FIRE EXTINGUISHER Inspect for full charge, proper working condition, and secure mounting. Replace if gage indicates low charge.
	24	WHEEL ASSEMBLY Clean and check for damage. Check that wheel bearings have been lubricated in accordance with LO 5-4320-272-12. Adjust the wheel bearings as instructed in paragraph 4-37.
	25	ENGINE COMPRESSION Check the compression as directed in paragraph 4-34.

Section VI. TROUBLESHOOTING

4-12. General

a. This section contains troubleshooting information for locating and correcting most of the operating troubles which are the responsibility of organizational maintenance. Each malfunction for an individual component, unit, or system is followed by a list of tests or inspections which will help you to determine probable causes and corrective actions to take. Perform the tests/inspections and corrective actions in the order listed.

b. This manual cannot list all malfunctions that may occur, nor all tests or inspections and corrective actions. If a malfunction is not listed or is not corrected by listed corrective actions, notify your supervisor.

c. Only those functions which are solely within the scope of organizational maintenance are listed. For troubleshooting procedures which are within the scope of operator/crew maintenance, refer to paragraph 3-7.

4-13. Organizational Maintenance Troubleshooting Chart

Refer to table 4-2 for troubleshooting which is allocated to organizational maintenance levels.

NOTE

Before you use this table, be sure you have performed all applicable operating checks.

Table 4-2. Troubleshooting

MALFUNCTION	TEST OR INSPECTION	CORRECTIVE ACTION
ENGINE		
1. ENGINE FAILS TO TURN OVER WHEN STARTING BUTTON IS DEPRESSED.		
	Step 1. Check for a weak or dead battery.	Charge or replace battery (para 4-23).
	Step 2. Inspect for loose or broken battery cables.	Tighten or replace broken battery cables.
	Step 3. Check for faulty starter pushbutton.	Replace faulty pushbutton (para 4-28).

Table 4-2. Troubleshooting-Continued

MALFUNCTION	TEST OR INSPECTION	CORRECTIVE ACTION
	Step 4. Check for defective starting motor.	Replace brushes if worn. Replace defective starting motor (para 4-27).
	Step 5. Check for internal seizure of the engine or pump.	Report seized engine or pump to direct support maintenance.
2. ENGINE TURNS OVER BUT FAILS TO START (NO SPARK).	Step 1. Check magneto breaker point opening.	Adjust breaker point gap (para 4-25).
	Step 2. Check for magneto breaker points sticking shut.	Replace or adjust breaker points (para 4-25).
	Step 3. Check for shorted or grounded magneto.	Replace magneto (para 4-25).
	Step 4. Check for defective capacitor.	Replace defective capacitor (para 4-25).
3. ENGINE TURNS OVER BUT FAILS TO START (GOOD SPARK).	Step 1. Check for clogged fuel lines and fittings.	Clean fuel lines (para 4-18).
	Step 2. Check for defective fuel pump.	Replace defective fuel pump (para 4-19).
	Step 3. Check for plugged vent in fuel tank cap.	Open fuel tank cap vent.
4. ENGINE RUNS BUT CONTINUALLY MISFIRES.	Step 1. Inspect for fouled or defective spark plug.	Replace spark plug (para 4-26).
	Step 2. Check for defective spark plug wire.	Replace wire (para 4-25).
	Step 3. Check for defective magneto.	Replace defective magneto (para 4-25).
5. ENGINE OVERHEATS.	Step 1. Check for missing or damaged air shrouding panels.	Repair minor damage. Notify direct support maintenance of major damage or missing panels.
	Step 2. Check for broken vanes on flywheel.	Report damage to direct support maintenance.
	Step 3. Check for late ignition timing.	Correct timing (para 4-25).
6. ENGINE RUNS BUT LACKS POWER.	Step 1. Check for incorrect ignition timing.	Correct timing (para 4-25).
	Step 2. Check for air leaks in fuel system.	Correct air leaks (para 4-18).
	Step 3. Check for restriction in air cleaner.	Remove restriction from air cleaner. Clean filter element if dirty; replace element if necessary (para 4-17).
7. ENGINE BACKFIRES.	Step 1. Check for improper ignition timing.	Correct timing (para 4-25).
8. ENGINE OPERATES ERRATICALLY.	Step 1. Check for improper fuel mixture.	Adjust carburetor (para 4-20).
	Step 2. Check for weak magneto capacitor.	Replace capacitor (para 4-25).
	Step 3. Inspect for too wide spark plug gap.	Regap spark plugs (para 4-26).
9. ENGINE WILL NOT IDLE.	Step 1. Check for improper carburetor adjustment.	Adjust carburetor (para 4-20).
	Step 2. Inspect for too close spark plug gap.	Regap spark plugs (para 4-26).
	Step 3. Check for weak capacitor.	Replace capacitor (para 4-25).
10. HIGH ENGINE OIL CONSUMPTION.	Step 1. Inspect for oil leaks.	Correct oil leaks.
	Step 2. Check for use of incorrect grade of oil.	Use oil recommended in LO 5-4320-272-12.

Section VII. MAINTENANCE OF EXHAUST SYSTEM

4-14. Description

The muffler (fig. 1-1) is a hollow cylinder containing internal baffles which break up the flow pattern of the exhaust gases expelled by the engine to provide quiet engine operation. It is mounted on top the engine and connected to the manifold exhaust port by a pipe nipple.

4-15. Muffler and Piping

a. Removal and Disassembly. Remove and disassemble the muffler and related parts from the engine by following the sequence indicated in figure 4-1.

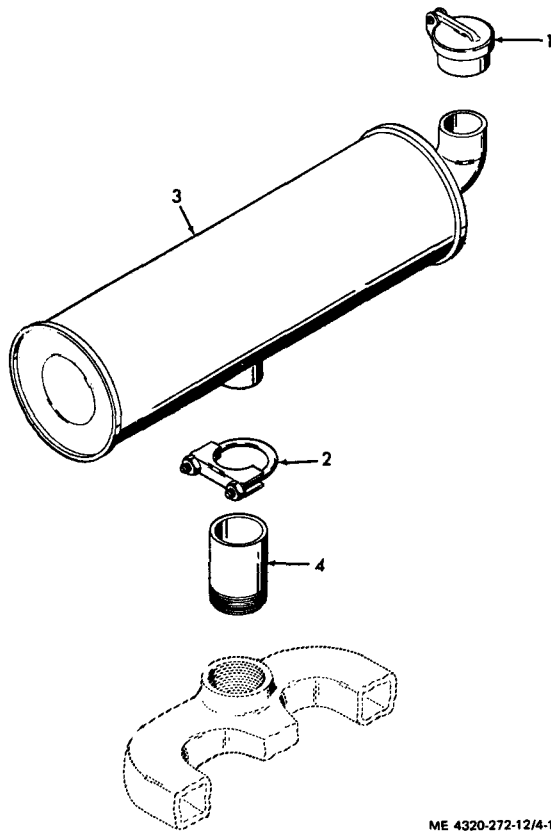

1. Weather cap
2. Clamp

3. Muffler
4. Pipe nipple

Figure 4-1. Muffler and piping, exploded view.

b. Cleaning and Inspection.

WARNING

Clean all parts in a well-ventilated area. Avoid inhalation of solvent fumes and prolonged exposure of the skin to cleaning solvent. Wash exposed skin thoroughly.

(1) Clean the muffler and exhaust piping with a wire brush. Wipe with a cloth dampened with cleaning solvent (fed. spec. P-D-680).

(2) Clean all remaining parts with cleaning solvent.

(3) Inspect the muffler for cracks, holes, severe rust, and other damage; replace a damaged muffler.

(4) Inspect the remaining parts for cracks, distortion, damaged threads, and other damage; replace damaged parts.

c. Reassembly and Installation. Reassembly of the muffler and piping is the reverse of disassembly. Refer to figure 4-1.

Section VIII. MAINTENANCE OF FUEL SYSTEM

4-16. Description

a. Air Cleaner. The air cleaner (fig. 1-1) is mounted on the left side of the flywheel housing. It is a dry-type unit which uses a porous paper element to screen the particles of dust and dirt from

the air before it enters the carburetor. A system of hoses, pipes, and clamps connects the air cleaner and carburetor. You maintain the air cleaner by cleaning and replacing the filter element when necessary.

b. Fuel Tank, Lines, and Fittings. The fuel system consists of a fuel tank (fig. 1-1) which is mounted on the trailer frame beside the engine. It incorporates a 3-way fuel source selector valve (6, fig. 2-2) to permit you to select fuel from the fuel tank or from an auxiliary source, whichever way the valve is operated. A fuel line connects the 3-way valve with the fuel pump.

c. Fuel Pump. The diaphragm-type, engine-driven fuel pump (7, fig. 4-4) is operated by a lobe on the camshaft. It is mounted on the top rear of the engine. Fuel is pumped through a strainer to the carburetor, which is mounted on the intake manifold.

d. Fuel Strainer. The fuel strainer (fig. 4-4) is mounted between the line from the fuel tank and the fuel pump. It is necessary to prevent sediment, dirt, and water from entering the carburetor. Inspect the fuel bowl frequently and empty out any dirt and water; wipe it dry with a clean cloth.

e. Carburetor. The side draft-type carburetor (3, fig. 4-7) controls the fuel-air mixture which is fed to the engine to meet the needs of the engine power requirements. A float system controls the level of the fuel in the carburetor float bowl. Adjustment screws are provided to permit regulation of the high-speed operation fuel mixture, the idle mixture, and the idle speed. Choking is controlled manually.

f. Governor. Engine speed is controlled by the inter-operation of the governor and carburetor. The centrifugal flyball governor rotates on a ball

bearing supported shaft in the upper part of the timing gear cover and is driven off the camshaft gear. As the engine speed increases or decreases, the governor transfers the centrifugal forces to axial movements which operate the governor control lever. The control lever is connected to the throttle control on the carburetor and as the engine tends to increase, the throttle is closed slightly, resulting in a decrease in engine speed. This decrease in engine speed causes a decrease in centrifugal forces which causes the governor to operate the control lever in the opposite direction. The governor lever then opens the carburetor throttle, tending to speed up the engine. In this manner, a balanced condition is reached and the engine speed remains constant, as determined by the throttle control setting. Adjustment of the governor is made by changing the tension of the spring which applies tension to the governor control lever. Tightening the spring tends to raise engine speed at any particular throttle control setting. Decreasing spring tension lowers the speed.

4-17. Air Cleaner and Piping

NOTE

The air cleaner element must be replaced after one year of service or after it has been cleaned six times, whichever comes first.

a. Removal and Disassembly.

(1) Remove and disassemble the air cleaner and related parts following the sequence indicated in figure 4-2.

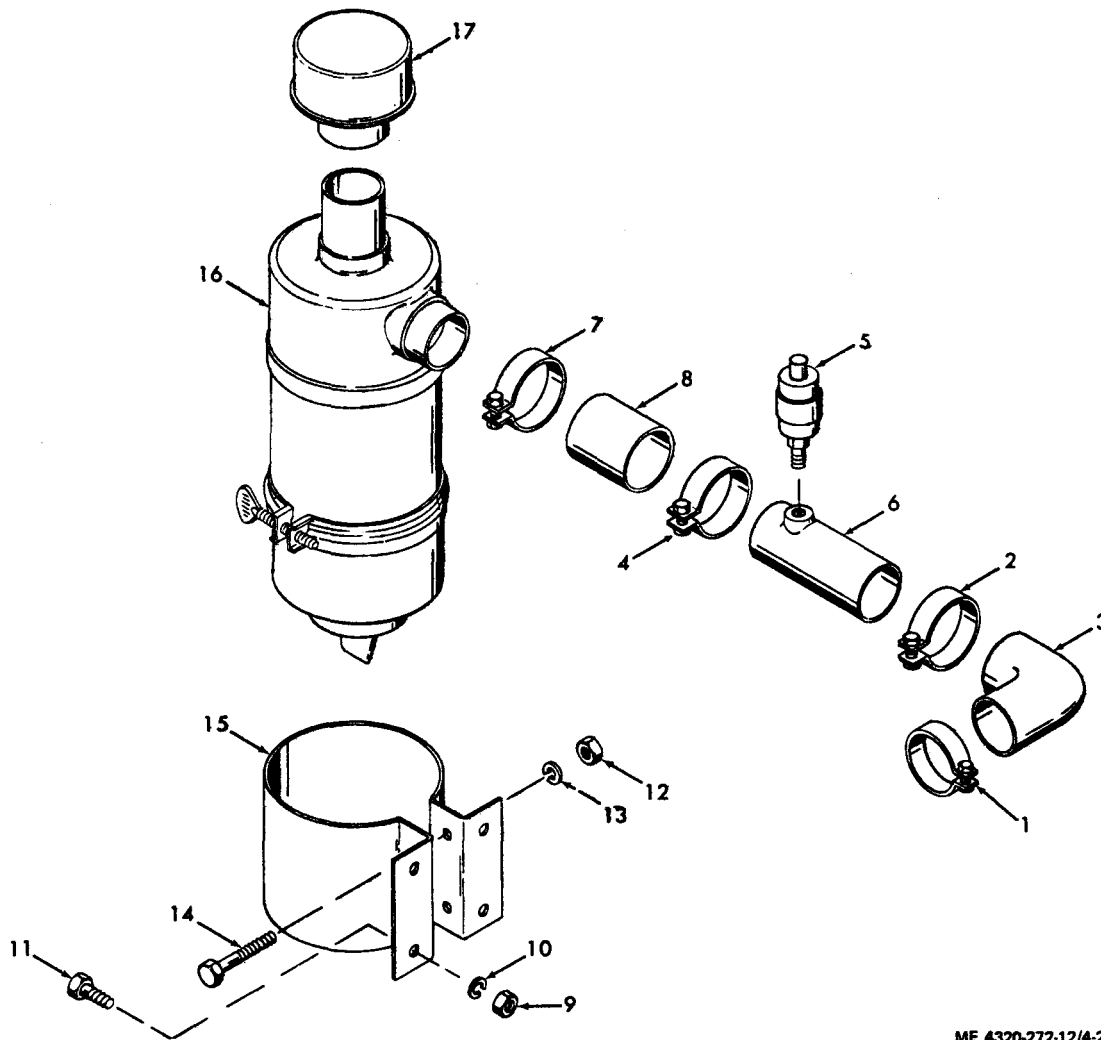

ME 4320-272-12/4-2

- | | |
|------------------------------|-------------------|
| 1. Clamp | 10. Lock washer |
| 2. Clamp | 11. Cap screw |
| 3. Elbow | 12. Nut |
| 4. Clamp | 13. Lock washer |
| 5. Air restriction indicator | 14. Cap screw |
| 6. Tube | 15. Bracket |
| 7. clamp | 16. Air cleaner |
| 8. Hose | 17. Air stack cap |
| 9. Nut | |

Figure 4-2. Air cleaner and piping, exploded view.

(2) Service your air cleaner as directed in subparagraph 3-9 a (3).

b. *Cleaning and Inspection.*

WARNING

Clean all parts in a well-ventilated area. Avoid inhalation of solvent fumes and prolonged exposure of the skin to cleaning solvent. Wash exposed skin thoroughly.

(1) Clean the exterior of the air cleaner and

air cleaner piping by wiping with a cloth dampened lightly with cleaning solvent (fed. spec. P-D-680); dry thoroughly.

(2) Inspect the air cleaner for dents, cracks, and leaking. Replace the air cleaner if the housing is damaged.

(3) Inspect the air cleaner piping for cracks or holes which could allow unfiltered air to enter the engine; replace any damaged parts.

(4) Inspect the air cleaner mounting parts for

cracks, distortion, and other damage; replace damaged parts.

c. Reassembly and Installation. Reassembly and installation is essentially the reverse of removal and disassembly. Refer to figure 4-2.

4-18. Fuel Tank, Lines, and Fittings

a. Removal and Disassembly. Remove and disassemble the fuel tank and related parts following the sequence indicated in figure 4-3. Pay particular attention to the following:

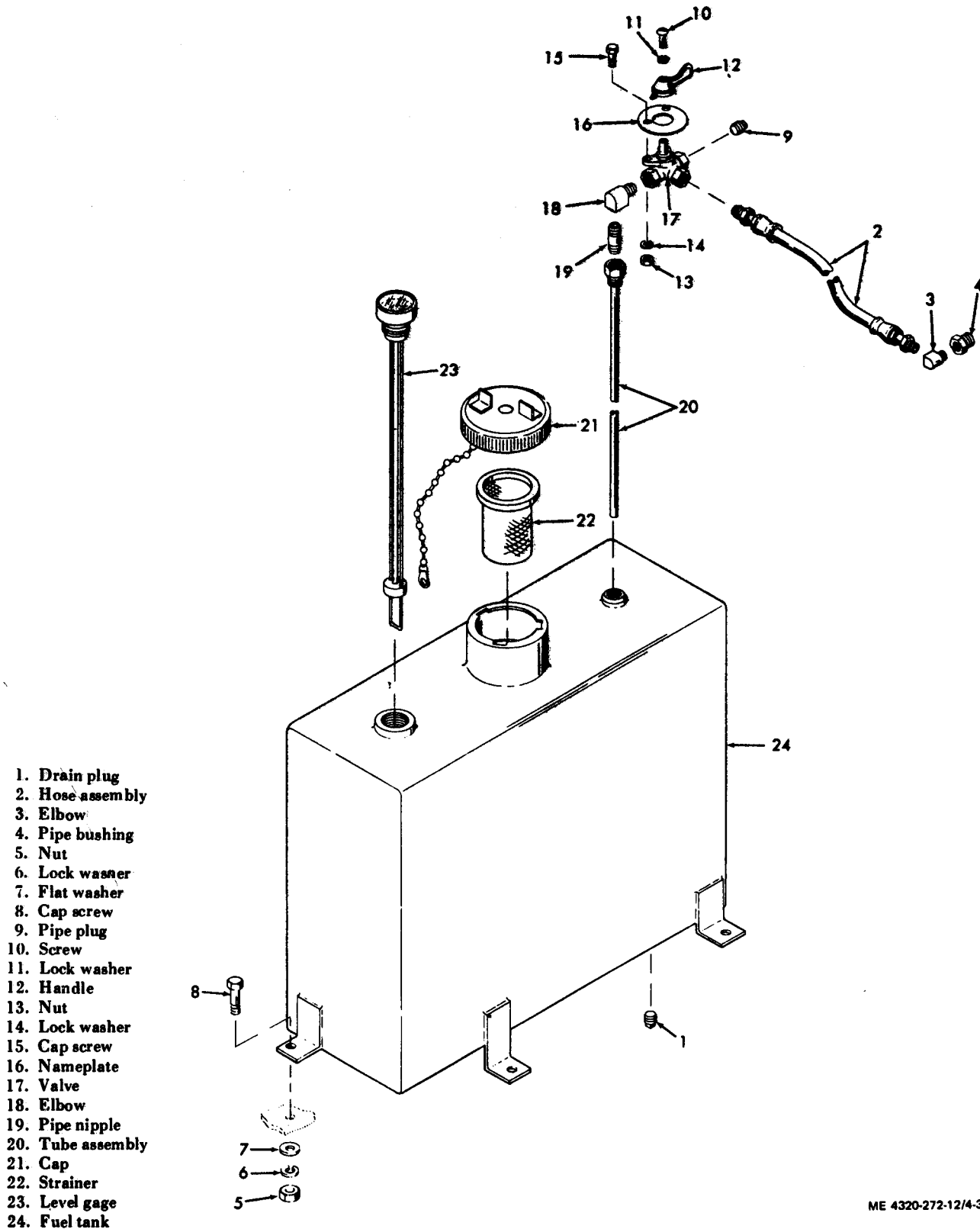

ME 4320-272-12/4-3

Figure 4-3. Fuel tank, lines, and fittings, exploded view.

(1) Disconnect auxiliary fuel lines, if used, and operate the fuel selector valve (17) to OFF.

(2) Disconnect and remove hose assembly (2) between valve and fuel strainer. Remove pipe elbow (3) and bushing (4).

(3) Remove the drain plug (1) from the bottom of the fuel tank. Be sure you have large enough container in which to drain the fuel.

(4) Remove the four cap screws (8), flat washers (7), lock washers (6), and nuts (5) that secure the fuel tank (24) to the trailer frame. Remove the fuel tank.

(5) You can now disassemble the fuel tank as shown in figure 4-3. Note that the liquid level gage (23) is threaded into the tank and that you can remove it by turning counterclockwise.

b. Cleaning and Inspection.

WARNING

Clean all parts in a well-ventilated area. Avoid inhalation of solvent fumes and prolonged exposure of the skin to cleaning solvent. Wash exposed skin thoroughly.

(1) Steam-clean the inside and outside of the fuel tank. Thoroughly flush with cleaning solvent (fed. spec. P-D-680).

WARNING

If conditions require emergency fuel tank repairs by welding or other methods involving heat or flame, all gasoline fumes must be purged from the tank before commencing repair. Applying heat or flame to a fuel tank containing gasoline residue may result in a violent explosion, causing injury or death to maintenance personnel.

(2) Inspect the fuel tank for cracks, dents, damaged threads, and broken weldments. Replace a damaged fuel tank.

(3) To remove embedded material from the strainer, you can use a soft-bristled brush.

(4) Clean all fuel lines and fittings with cleaning solvent (fed. spec. P-D-680). You should

blow through the lines with compressed air to make sure they are clear.

(5) Inspect the hose for cracks, fraying, and damaged threads; replace a damaged hose.

(6) Inspect the 3-way valve for difficult operation and for cracked or damaged threads; replace a damaged valve.

(7) Inspect all other parts for cracks, distortion, and damaged threads; replace any damaged parts.

(8) Inspect the fuel level gage for free operation of the float and proper registration of the level indicator. Replace gage if damaged.

c. Reassembly and Installation. Reassemble and install the fuel tank fuel lines, and fittings in reverse order of removal and disassembly. Pay particular attention to the following:

(1) Be sure that the drain plug (1, figure 4-3) is installed and all fittings are tightened properly before you fill the tank with fuel.

(2) After you have partially filled the tank with fuel, check for leaks of the system. Correct any leaks noted.

4-19. Fuel Pump and Strainer

NOTE

You shall remove the fuel pump only when required to replace a leaking gasket or when tests indicate that the fuel pump is faulty.

a. Testing. To test the fuel pump for faulty operation, proceed as follows:

(1) With engine off, assure that it will not start by tripping oil pressure safety switch. Disconnect fuel line at carburetor.

(2) Turn the engine over with the starter. A properly operating fuel pump will squirt out fuel with some force. Replace a faulty operating or damaged fuel pump.

b. Removal and Disassembly. Remove and disassemble the fuel pump and fuel strainer following the sequence indicated in figure 4-4. Pay particular attention to the following:

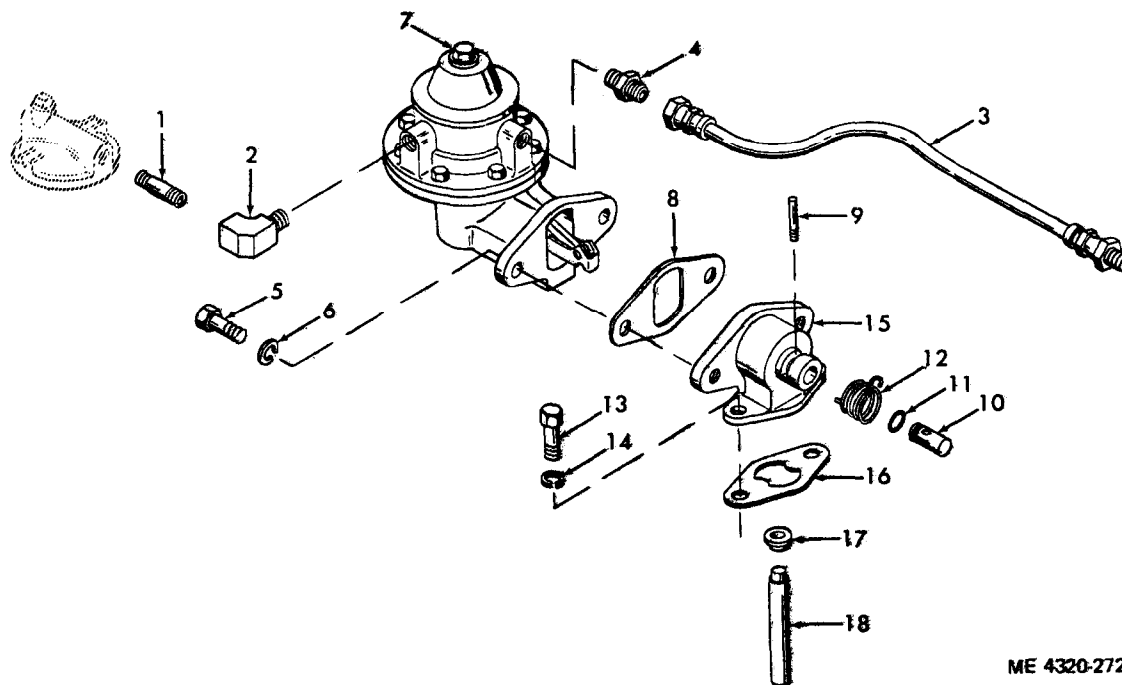

ME 4320-272-12/4-4

1. Pipe ripple
2. Elbow
3. Tribe assembly
4. Adapter
5. Cap screw
6. Lock washer
7. Fuel pump
8. Gasket
9. Primer handle

10. Shaft
11. Preformed packing
12. Spring
13. Gap screw
14. Lock washer
15. Adapter
16. Gasket
17. Plunger cap
18. Plunger

Figure 4-4. Fuel pump and fuel strainer, exploded view.

(1) Disassemble the fuel strainer and service as instructed in paragraph 3-9c.

(2) Disconnect the fuel lines to the fuel strainer.

c. Cleaning and Inspection.

(1) Service the fuel strainer as directed in subparagraph 3-9 c.

WARNING

Clean all parts in a well-ventilated area. Avoid inhalation of solvent fumes and prolonged exposure of the skin to cleaning solvent. Wash exposed skin thoroughly.

(2) Clean the fuel pump with a cloth dampened with cleaning solvent (fed. spec. P-D-680); wipe dry.

(3) Clean all fuel lines and fittings with cleaning solvent. Blow through them with compressed air to assure all are clear.

(4) Inspect the fuel pump for cracks, damaged threads, and other obvious damage. If

you removed the fuel pump to replace the gaskets (8 and 16, fig. 4-4), operate the cam follower lever to check for faulty movement. Replace the fuel pump if defective.

(5) Inspect all remaining parts for damage; replace any damaged parts.

d. Reassembly and Installation. Reassemble and install the fuel strainer and fuel pump in the reverse order of disassembly; refer to figure 4-4. Pay particular attention to the following:

(1) After installing the fuel strainer and fuel pump, make sure you connect the fuel line to the strainer and that all fittings are tight.

(2) Operate the engine and check for leaks. Correct any leaks noted.

4-20. Carburetor

a. Adjustment. If troubleshooting indicates that the carburetor is responsible for faulty engine operation, you can adjust the carburetor as follows:

(1) Start the engine and allow it to warm up to operating temperature.

(2) Adjust the main adjusting screw (fig. 4-5). This adjustment determines the amount of fuel available for high-speed operation. Adjust as follows:

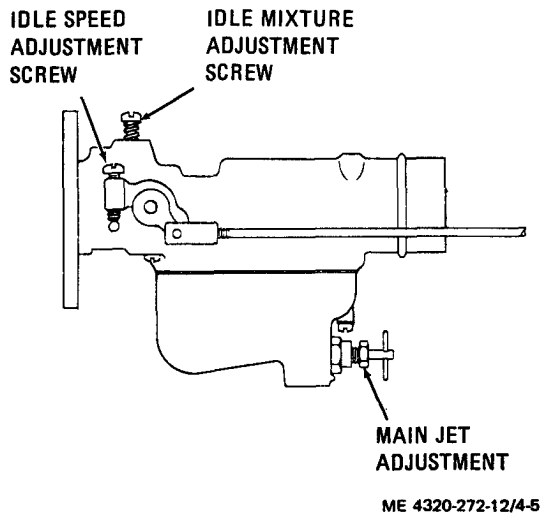

Figure 4-5. Carburetor adjustments.

(a) Adjust the throttle control of the pump to set the carburetor throttle at about one-fourth open.

(b) Turn the main adjusting screw clockwise to reduce the fuel to the engine until the engine begins to miss due to a lean fuel mixture.

(c) Turn the adjusting screw counterclockwise until the engine runs smoothly without missing.

(3) Adjust the idle mixture adjustment screw (fig. 4-5). This adjustment controls the amount of air admitted to the idling system which functions only at low speeds. You should adjust as follows:

(a) With the engine at idle, turn the idle mixture adjustment screw counterclockwise to cut off air, making the fuel mixture richer until the engine starts to run roughly due to excessively rich mixture.

(b) Turn the adjustment screw clockwise to obtain the smoothest idle operation possible.

(c) By observing the engine vacuum gage on the control panel, you can adjust the screw for the highest engine vacuum.

(4) Adjust the idle speed adjustment screw (fig. 4-5). Turn the screw clockwise or counterclockwise as necessary to provide 1400 ± 50 rpm idle speed when the pump throttle control is set to idle.

b. Removal.

NOTE

Remove carburetor only if troubleshooting indicates faulty operation requiring replacement.

(1) Disconnect the carburetor throttle lever from the governor control rod linkage. Refer to figure 4-6.

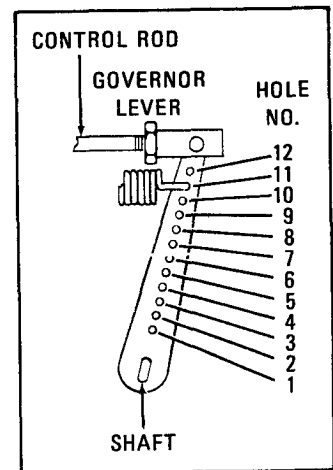
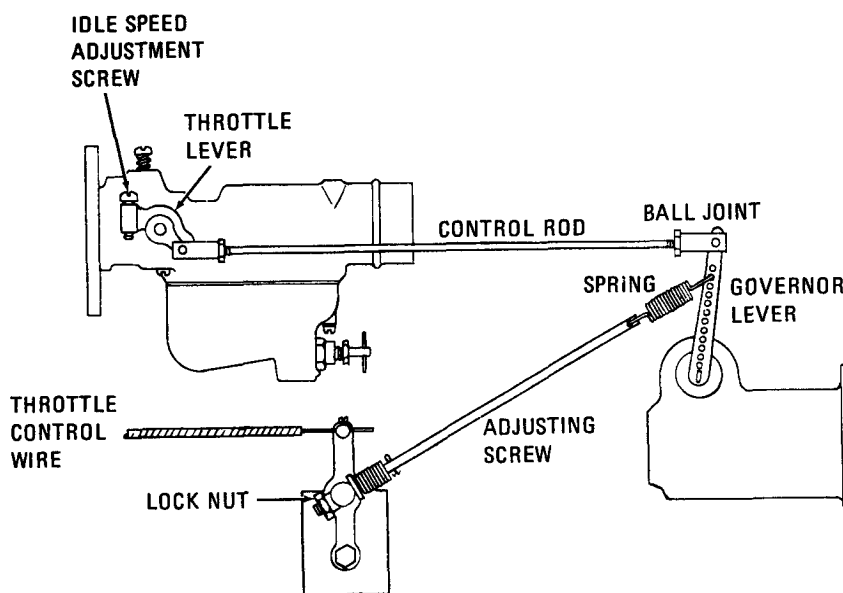

ME 4320-272-12/4-6

Figure 4-6. Governor and carburetor linkage.

(2) Disconnect the choke control wire from the carburetor choke lever.

(3) Disconnect the fuel line from the carburetor (para 4-18 a).

(4) Disconnect the air cleaner hose from the carburetor (para 4-17 a).

(5) Remove the two cap screws (1, fig. 4-7) and lock washers (2) that secure the carburetor to the manifold; remove the carburetor (3) and gasket (4).

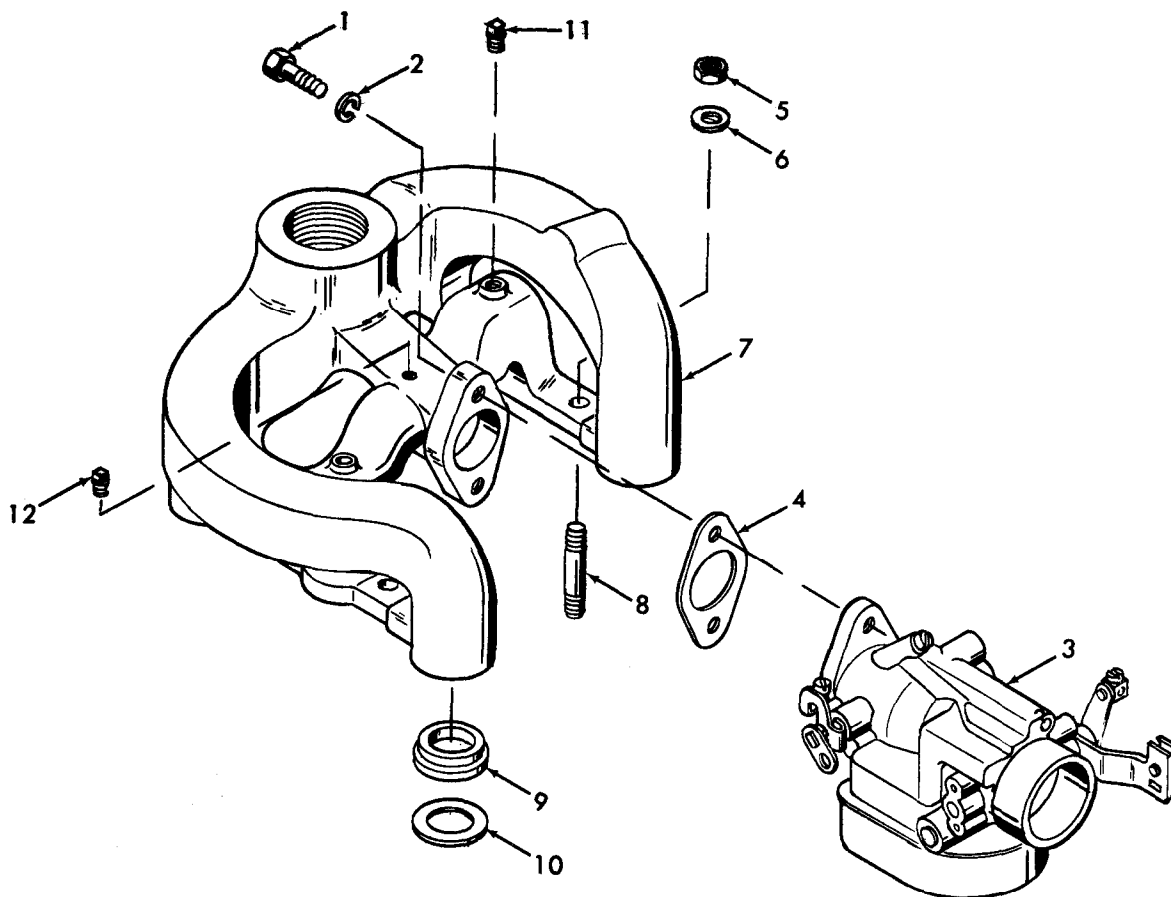

ME 4320-272-12/4-7

- 1. Cap screw
- 2. Lock washer
- 3. Carburetor
- 4. Gasket
- 5. Nut
- 6. Flat washer

- 7. Manifold
- 8. Stud
- 9. Insert
- 10. Gasket
- 11. Pipe plug
- 12. Pipe plug

Figure 4-7. Manifold and carburetor, exploded view.

c. *Cleaning and Inspection*

WARNING

Clean all parts in a well-ventilated area. Avoid inhalation of solvent fumes and prolonged exposure of the skin to cleaning solvent. Wash exposed skin thoroughly.

(1) Clean the exterior of the carburetor with a cloth dampened with cleaning solvent (fed. spec. P-D-680); dry thoroughly.

(2) Inspect the carburetor for cracks and other obvious damage. Check the operation of the throttle lever and choke lever. They must operate freely, without binding. Replace the carburetor if you determine that it is defective.

d. *Installation.* Install the carburetor by reversing the removal procedure. Note the following:

(1) Make sure there are no air leaks between the carburetor and air cleaner. Air leaks will allow

dust and dirt to enter the engine, causing rapid engine wear.

(2) When you connect the choke control wire to the carburetor, adjust it so that the choke lever can move through its full operating range as the choke control on the instrument panel is operated.

(3) Adjust the throttle linkage from the governor as directed in paragraph 4-21.

4-21. Governor Adjustment

To insure proper operation of the governor and carburetor, refer to figure 4-6 and adjust the throttle linkage as follows:

NOTE

Before you adjust the throttle linkage, you must make sure the idle speed adjusting screw is set for the proper idle speed.

a. Disconnect the control rod ball joint from the governor lever.

b. Push the control rod toward the carburetor as far as it will go, causing the throttle to open fully.

c. Move the governor lever as far as possible in the same direction. Holding both parts in these

positions, screw the ball joint on or off the control rod until you can align the right angle stud on the ball joint fitting with the top hole on the governor lever, then screw fitting in two additional turns.

d. Insert ball joint stud into the top hole in the governor lever, install and tighten lock nuts.

e. With the governor lever pushed toward the carburetor as far as it will go, be sure you have approximately 1/16-inch clearance between the throttle lever and the stop pin on the carburetor. If the clearance is not correct, you can adjust it by turning control lever ball joint farther on or off control rod; refer to above subparagraph c.

f. To adjust the maximum operating speed of the engine you must be sure the spring is hooked into the proper hole in the governor lever. Hook the spring in hole No. 11 (fig. 4-6), the eleventh hole up from the lever shaft. There are 12 spring mounting holes. With engine operating and throttle fully open, the full-load speed will be approximately 2350 rpm.

Section IX. MAINTENANCE OF ELECTRICAL SYSTEM

4-22. Description

a. *Battery.* The electrical system includes the battery box which houses one 24-volt, lead-acid-type storage battery to power the 24-volt, negative ground electrical system. Battery output is used to energize the electrical starting motor to start the engine. The battery charge is partially depleted as the engine is started and is restored by the battery charging system consisting of the alternator and voltage regulator.

b. *Alternator and Regulator.* The flywheel alternator is a permanent-magnet type and has no brushes, commutator, belts, or adjustments. The alternator output is controlled through the voltage regulator, depending upon the state of battery charge. When the battery charge is low, the voltage regulator increases the output of the alternator; when the battery charge is normal, the output of the alternator decreases to near zero.

CAUTION

Though this engine is equipped with a reverse polarity protector, you should take special precautions when connecting and disconnecting electrical leads and cables. Do not reverse battery connections. Do not operate engine with battery disconnected from the system. Make sure you connect any booster batteries properly. When you use a fast battery charger, disconnect at least one battery lead. Failure to follow these

instructions may damage the alternator rectifiers, voltage regulator, and wiring.

c. *Magneto.* The magneto is timed to the engine and is driven by the idler gear. Voltage induced by the magneto coils is applied to the spark plug of the appropriate cylinder at the required instant by the distributor rotor in the magneto. The breaker points open at the correct instant to assure a hot spark to the spark plug at this time. The magneto also contains automatic spark advance provisions so that the spark will occur sooner during high speed operation. This is necessary for smooth engine performance.

d. *Spark Plugs.* Four radio-shielded spark plugs receive the spark from the magneto and ignite the fuel-air mixture in the appropriate cylinder. The firing order of the cylinders is 1-3-4-2. When you view the engine from the flywheel end, the number 1 cylinder is the one nearest the flywheel on the left bank of cylinders. The number 3 cylinder is the other cylinder in this bank. The number 2 cylinder is the one nearest the flywheel in the right bank of cylinders and the number 4 is the other cylinder in this bank.

e. *Starting Motor.* The starting motor has a Bendix drive gear which engages the flywheel ring gear when the starter switch pushbutton is depressed. The starting motor disengages when the button is released. You maintain die starting motor by replacing the brushes when worn.

f. *Oil Pressure Safety Switch.* The oil pressure

safety switch is mounted on the control panel and connects in a line from the oil pressure gage. The operating oil pressure is 4 to 5 psi. When the oil pressure drops to 1 psi, the oil pressure safety switch is tripped and closes the ground circuit to the magneto to stop the engine. This protects the engine from wear due to lack of oil. You must reset the switch plunger after each engine shutdown before you can restart the engine. The spring reset clip will kick out after the engine starts and sufficient oil pressure builds up. After that the switch will be operative.

g. Control Panel. The engine controls and instruments are mounted on the control panel which is located on the pump piping assemblies. Refer to figure 1-3 for the wiring diagram showing the electrical connections between the engine and controls. The function of the controls and instruments is described in table 2-1.

h. Starter Switch. The starter switch, mounted on the control panel, closes the circuit to energize the starting motor. When the pushbutton is released, the starting motor deenergizes. Care should be taken that you do not energize the starting motor while the engine is running.

i. Magneto Switch. When you depress the magneto switch on the control panel, it will ground the magneto and stop the engine. This switch is in the same circuit as the oil pressure safety switch.

4-23. Battery, Battery Box, and Leads

a. Service. To charge battery, proceed as follows:

(1) Remove caps and check the electrolyte level in each cell. If any are low, fill to proper level with distilled water.

WARNING

Do not smoke or use an open flame in

the vicinity when servicing the battery. Batteries generate hydrogen gas, which is highly explosive.

(2) Start engine and allow it to run for 10 to 15 minutes. Stop the engine and check the battery with a hydrometer. A fully charged battery shall have a minimum specific gravity of 1.275 at 75° F.

(3) If the specific gravity of the electrolyte is less than 1.250, the battery must be charged before use. When you charge the battery, use a constant current charger. Check the specific gravity of the electrolyte every 30 minutes. The battery is fully charged when you get a constant specific gravity reading for three 30-minute intervals.

CAUTION

Constant-current battery charging is always preferred. If you must use a constant-potential charger, battery temperatures must be maintained at less than 130°F by interrupting the charging procedure as this temperature is approached.

(4) During charging, check the electrolyte level frequently. Add distilled water when necessary to maintain the battery electrolyte level. Continue charging after adding water to assure proper mixing of the solution.

(5) Charge the battery a minimum of once each month when the battery is not in service. If the battery fails to take or maintain a charge, replace it.

b. Removal and Disassembly.

(1) Remove two wing nuts (1, fig. 4-8) that secure cover (2) to the battery box (10); remove cover.

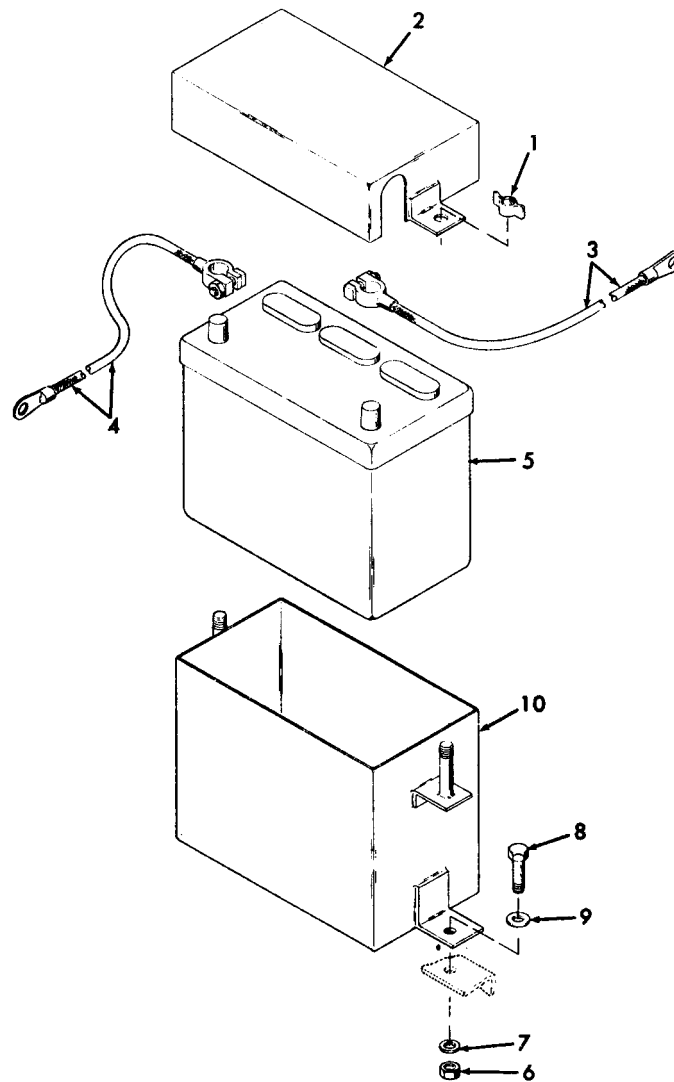

ME 4320-272-12/4-8

KEY to fig. 4-8:

- 1. Wing nut
- 2. Cover
- 3. Battery cable
- 4. Battery ground cable
- 5. Battery

- 6. Nut
- 7. Lock washer
- 8. Cap screw
- 9. Flat washer
- 10. Battery box

Figure 4-8. Battery box and battery, exploded view.

(2) Disconnect the cables (3 and 4) from the battery (5).

(3) Lift the battery from the battery box.

(4) You can now remove the battery box (10) and ground cable (4) by removing cap screws (8), flat washers (9), nuts (6), and lock washers (7).

c. Cleaning and Inspection.

(1) Clean the battery top and the cable ends with a solution of water and baking soda to neutralize any acid on the parts. Prevent the solution from entering the battery.

WARNING

Clean all parts in a well-ventilated area. Avoid inhalation of solvent fumes and prolonged exposure of the skin to cleaning solvent. Wash exposed skin thoroughly.

(2) Flush the metallic parts with a solution of water and baking soda to neutralize any spilled acid. Remove any greasy or gummy deposits with a cloth dampened with cleaning solvent (fed. spec. P-D-680).

(3) Inspect all parts for cracks, corrosion, damaged paint, stripped threads, and other damage. Touch up damaged paint. Replace damaged parts.

(4) If necessary, service the battery as directed in subparagraph *a* above.

d. Reassembly and Installation. Refer to figure 4-8 and install the battery, battery box, and cables in the reverse order of removal. After installation, be sure that you coat the battery terminals with GAA lubricant or petroleum jelly to prevent corrosion.

4-24. Alternator and Regulator

Testing of the alternator and components shall be done while the parts are mounted on the engine. The rectifier and regulator modules and the isolation diode are grounded to the engine so that they cannot be tested while mounted at a remote location. Before conducting the following tests to determine the condition of the components, check to insure that you have good continuity between the modules and the engines. These are static tests which do not require that you run the engine. Disconnect battery leads and uncouple the connectors that connect the modules to the stator leads.

a. You can check the operation of the battery charging system by observing the ammeter. The ammeter should indicate a high charging rate immediately after starting. After a few minutes the ammeter should return to near zero. If the ammeter does not operate in this manner or if it indicates a discharge rate, perform checks in subparagraphs *b* through *d* below.

b. To check for stator continuity, use a multimeter with R x 1 scale (minimum sensitivity of 20,000 ohm / volts), and check as follows:

(1) With positive meter probe connected to black wire No. 1 and negative probe connected to black wire No. 2, the multimeter should indicate approximately 1.00 ohm resistance. Replace stator if multimeter indicates a short (no resistance) or open (infinite resistance) circuit.

(2) With positive meter probe connected to black wire No. 1 and negative probe connected to the dark blue wire (center tap), the resistance should be approximately 0.50 ohm.

(3) With positive meter probe connected to black wire No. 2 and negative probe connected to the dark blue wire (center tap), the resistance should be approximately 0.50 ohm.

(4) With the positive meter probe connected to black lead No. 1 and negative probe connected to the red lead, the resistance should be 2.75 ohms.

(5) With the positive meter probe connected to black lead No. 2 and negative probe connected to the red lead, the resistance should be 1.75 ohms.

(6) If any of these tests indicate a short or open circuit, the stator must be replaced. Refer trouble to direct and general support maintenance.

(7) Any connection between a lead and engine ground should indicate infinite resistance. Any other reading indicates that a short circuit exists and the stator must be replaced.

c. To check the rectifier module, which you can distinguish from the regulator by the two black leads, use a multimeter and static check continuity as follows:

(1) With the positive meter probe connected to the engine ground and the negative probe connected to black lead No. 1, the meter should indicate 5 to 15 ohms resistance.

(2) With the positive meter probe connected to black lead No. 1 and the negative probe connected to the engine ground, the resistance shall be infinite. Any other reading indicates that a short circuit exists and the rectifier must be replaced. Report trouble to direct and general support maintenance.

(3) With the positive meter probe connected to the engine ground and the negative probe connected to black lead No. 2, the resistance shall be 5 to 15 ohms.

(4) With the positive meter probe connected to black lead No. 2 and the negative probe connected to the engine ground, the resistance shall be infinite. Any other reading indicates that a short circuit exists and the rectifier must be replaced.

d. Check the regulator module, which you can distinguish from the rectifier module by the red and black leads. Using a multimeter, all continuity checks shall indicate infinite resistance. Any other reading indicates that a short circuit exists and the regulator must be replaced. Report trouble to direct and general support maintenance. The multimeter probe connections shall be as follows:

(1) Positive probe connected to red lead.
Negative probe connected to engine ground.

(2) Positive probe connected to engine ground.
Negative probe connected to red lead.

(3) Positive probe connected to red lead.
Negative probe connected to black lead.

(4) Positive probe connected to black lead.
Negative probe connected to red lead.

(5) Positive probe connected to black lead.
Negative probe connected to engine ground.

4-25. Magneto

a. Checking Magneto Spark. You can test the strength of the magneto ignition spark by disconnecting the number 1 ignition wire from the spark plug and holding the terminal 1/8 inch away from the air shroud or any other metal part of the engine. Using the starting crank, slowly turn the engine over two complete revolutions and watch for

the spark discharge which should occur during the cycle, at the instant the impulse coupling on the magneto snaps. Repeat this check with each of the other ignition wires.

b. Replacing and Adjusting Breaker Point Assembly.

(1) Remove the screws (21 and 22, fig. 4-9) that secure the end cap assembly (23) to the housing (43). You can remove the end cap from the magneto without disconnecting the spark plug cables (4 thru 7). Remove the end cap assembly. Remove and discard the end cap gasket (24).

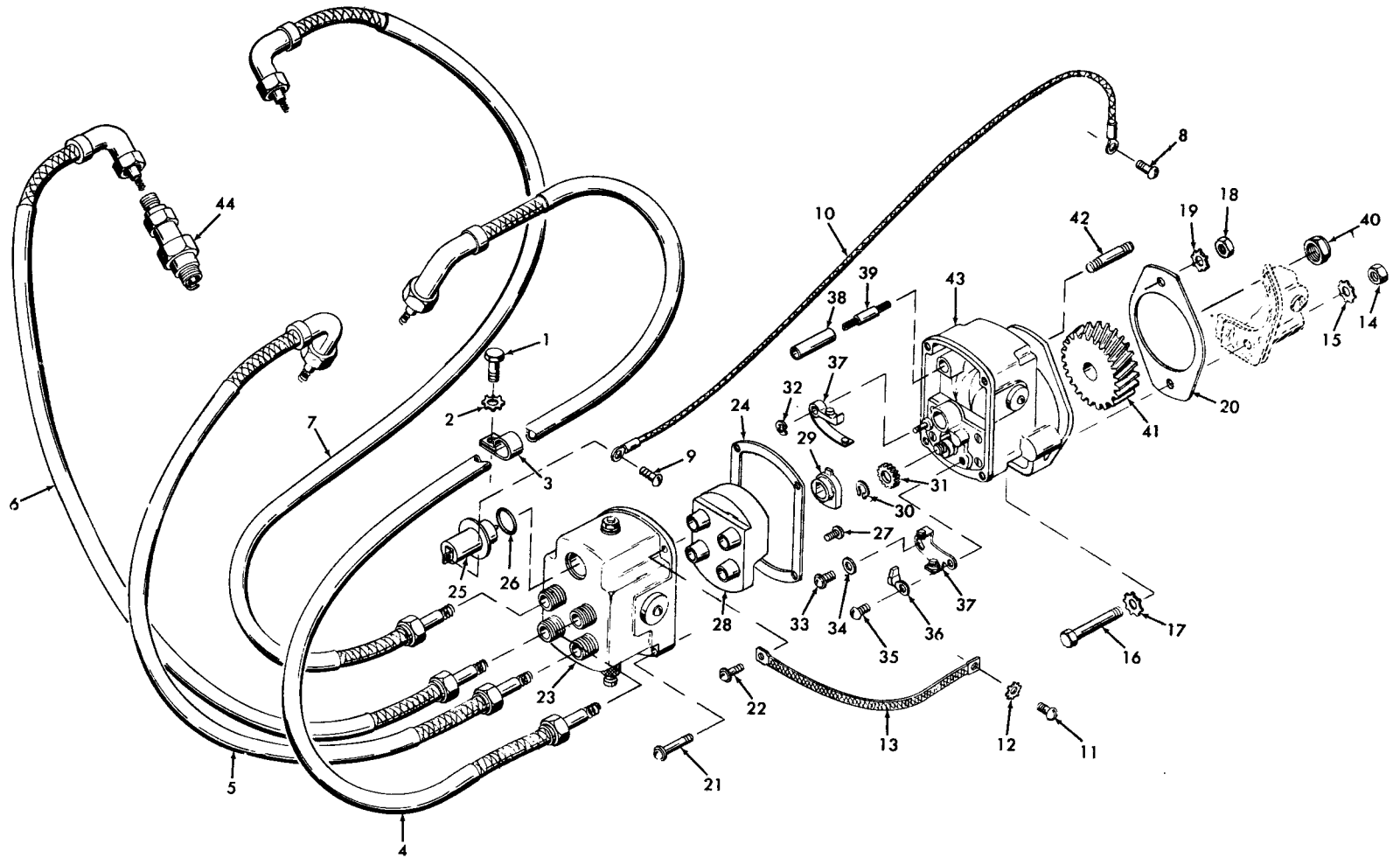

- 1. Cap screw
- 2. Lock washer
- 3. Cable clip
- 4. No. 1 spark plug cable
- 5. No. 3 spark plug cable
- 6. No. 4 spark plug cable
- 7. No. 2 spark plug cable
- 8. Screw

- 9. Screw
- 10. Ground switch lead
- 11. Screw
- 12. Lock washer
- 13. Ground strap
- 14. Nut
- 15. Lock washer

- 16. Cap screw
- 17. Lock washer
- 18. Nut
- 19. Lock washer
- 20. Gasket
- 21. Screw
- 22. Screw
- 23. End cap assembly
- 24. Gasket
- 25. Capacitor
- 26. Preformed packing
- 27. Screw
- 28. Distributor block
- 29. Rotor

- 30. Retaining ring
- 31. Rotor gear
- 32. Retaining ring
- 33. Screw
- 34. Flat washer
- 35. Screw
- 36. Cam wick

- 37. Breaker point assembly
- 38. Insulator
- 39. High tension lead
- 40. Nut
- 41. Magneto gear
- 42. Stud
- 43. Magneto housing
- 44. Spark plug

Figure 4-9. Ignition system, exploded view.

(2) Disconnect the ground switch lead (10) from the capacitor (25). Remove the capacitor and preformed packing (26) from the end cap assembly. Discard both the capacitor and preformed packing.

(3) Remove the screws (33 and 35), flat washer (34), and retaining ring (32) that secure the breaker point assembly (37) and cam wick (36) to the bearing support. Remove the breaker point assembly.

(4) Inspect the breaker points for evidence of pitting or pyramiding. You can use a small tungsten file or fine stone to resurface the points. You must replace badly worn or pitted points.

(5) Install new or resurfaced breaker point assembly on bearing support, using the screws (33 and 35), flat washer (34), and retaining ring (32). Leave the mounting screws just loose enough to permit adjustment. Be sure you install the cam wick (36).

(6) Rotate the engine by hand to locate the breaker arm on the high point of the cam. Using a feeler gage, set the breaker point at maximum opening of 0.015 inch. Make the adjustment with a screwdriver inserted into the slot at the bottom of the contact plate, and pivoting between the two small bosses on the bearing support. Hold the parts in place while you tighten the mounting screws. Make a final check of the breaker point gap to be sure you have maintained the correct adjustment.

(7) If the cam is dry, coat it with a light coat of grease.

(8) Before you reinstall the end cap, clean the contact surfaces between the cap and the housing. Using a new gasket (24), mount the end cap on the housing. Make sure the high tension lead (39) and insulator (38) are properly installed before securing cap. Secure end cap to housing with screws (21 and 22). Make sure the ground strap (13) is mounted to the magneto by screw (22).

(9) Install new capacitor (25) and preformed packing (26).

c. Removal. Remove the magneto for servicing or replacement as follows:

(1) Disconnect the shielded spark plug cables (4, 5, 6, and 7, fig. 4-9) from the magneto. Disconnect the ground switch lead (10) and disconnect ground strap (13) by removing screw (11) and lock washer (12).

(2) Remove the cap screw (16), lock washers (15 and 17), and nut (14). Remove nut (18) and lock washer (19). Now you can withdraw the magneto and gasket (20) from the gear housing.

d. Disassembly. Disassemble the magneto only far enough for you to install the parts included in the major repair kit, following the sequence indicated in figure 4-9. Pay particular attention to the following:

(1) Disassemble magneto as you would to remove breaker points; refer to subparagraph *b* above, steps (1) through (3).

(2) Remove distributor rotor (29) from distributor gear assembly.

(3) Remove the distributor block (28) by removing four screws (27) securing block to the end cap.

e. Cleaning and Inspection.

WARNING

Clean all parts in a well-ventilated area. Avoid inhalation of solvent fumes and prolonged exposure of the skin to cleaning solvent. Wash exposed skin thoroughly.

(1) If a repair kit is available and is being installed, discard all removed parts which have replacements in the kit. Clean the loose metallic parts with cleaning solvent (fed. spec. P-D-680); dry thoroughly. Clean the remaining parts with ac cloth dampened lightly with solvent. You must take care not to saturate the coil in the magneto housing.

(2) Inspect the end cap for cracks, burned terminals, signs of arcing, and other damage.

(3) Rotate the rotor shaft and check for binding or rough operation. Check for play between the shaft and bearings. Replace the magneto if more than just perceptible play exists.

(4) Inspect the magneto gear (41) for worn, cracked, or broken teeth.

(5) Inspect the magneto housing for cracks, distortion, and damaged threads. Check that the coil is firmly wedged in the frame. Check the coil for damaged insulation, gouges, and other damage.

(6) If you find parts damaged that are not included in the repair kit, replace with a new magneto assembly.

f. Reassembly. During reassembly, install all of the new parts that are contained in your repair kit, to replace the parts which were removed from the magneto. Reassembly is essentially the reverse of disassembly. Refer to figure 4-9. Note the following:

(1) Before you install the end cap, make sure the high tension lead (39) is properly installed in the distributor block and in the receptacle in the coil.

(2) Install and adjust the breaker point assembly (37) as directed in subparagraph *b* above.

g. Installation and Magneto Timing. Timing the magneto to the engine is a critical step of installation procedure. Install and time the magneto as follows:

(1) Remove the screen over the flywheel air intake opening by removing the screws holding the screen in place. This will expose the timing marks on the flywheel and shroud. Refer to figure 4-10.

FIRING ORDER 1 - 3 - 4 - 2

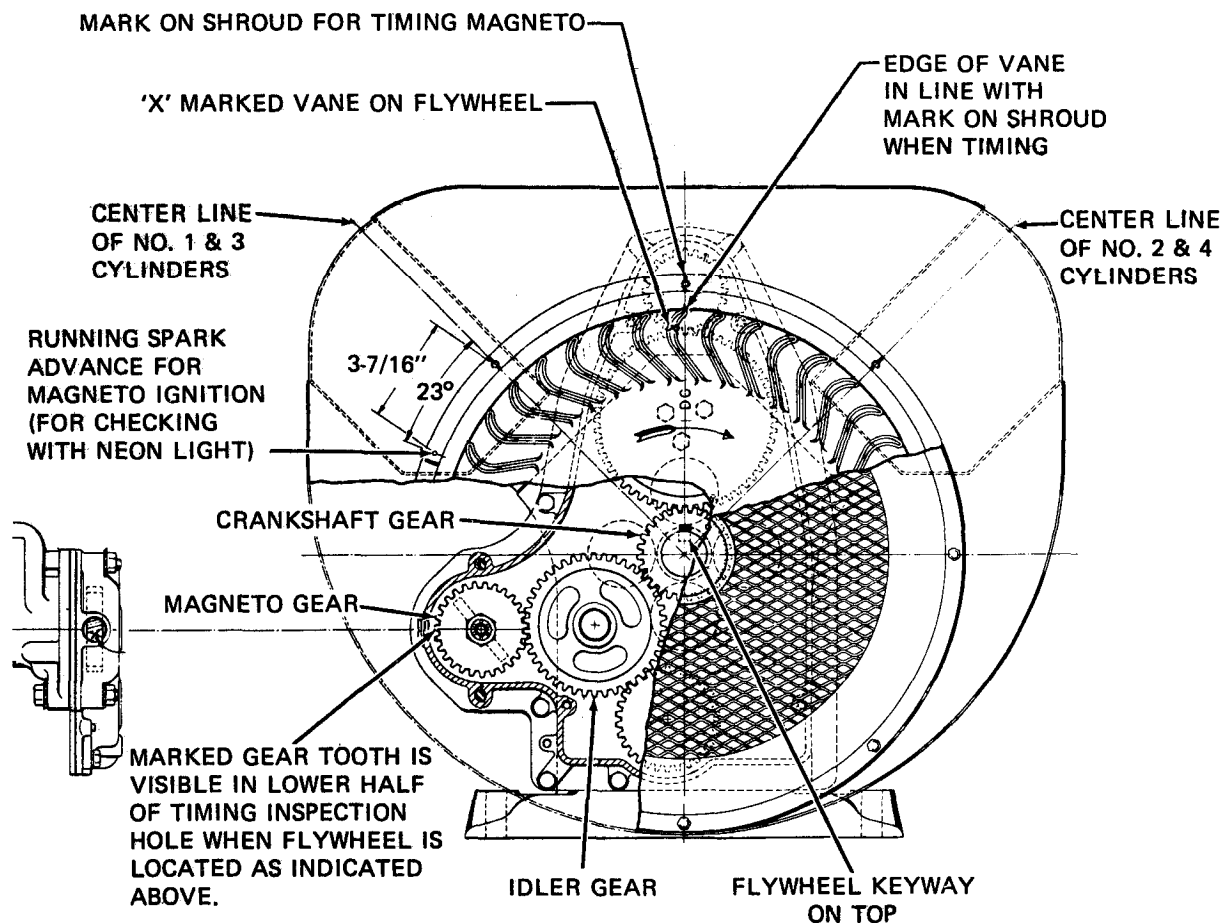

ME 4320-272-12/4-10

Figure 4-10. Magneto timing.

(2) Remove the spark plug from the number 1 cylinder. The firing order is marked on the shrouding. Put your thumb over the spark plug hole and crank the engine until the cylinder starts on the compression stroke. This is indicated by air being compressed against your thumb as the piston rises in the cylinder.

(3) To set the piston on top-dead-center, continue cranking the engine until the DC mark on the flywheel is aligned with the timing mark on the shroud. The edge of the X-marked vane will also be aligned with the timing mark. Hold the engine at this setting.

(4) Disconnect the oil line and remove the pipe elbow from the gear cover at the magneto mounting flange.

(5) With the magneto still removed from the engine, you must now determine the number 1

cylinder firing position of the magneto. Insert the ignition cable into the number 1 tower terminal as marked on the magneto end cap. Mount the magneto in a vise thoroughly lined with soot cloths. Turn the magneto gear in a clockwise rotation, tripping the impulse coupling, until the number 1 terminal sparks, then hold the gear in this position.

(6) Remove the magneto from the vise. Mount the magneto and gasket (20, fig. 4-9) on the engine, meshing the gears so that when the magneto is in place, the gear tooth marked with an X will be visible through the lower half of the inspection hole in the gear cover. Refer to figure 4-10. Moderately tighten the securing cap screw (6, fig. 4-9), lock washers (15, 17, and 19) and nuts (14 and 18). Connect the spark plug cables.

(7) Start the engine and idle it at 1400 ± 50 rpm. If the engine fails to start, it is probable due to

faulty ignition timing. You should recheck as directed above.

(8) With the engine running at 1400 ± 50 rpm, you can check for proper spark advance with a timing light. The proper spark advance is indicated on the shroud by a $1/8$ inch hole 23° before the vertical centerline on the number 1 and 3 cylinders. For easier recognition of the X-marked vane, you should whiten it with chalk or paint. Connect the timing light to the number 1 spark plug and check that the indication on the flywheel is aligned with the spark advance mark on the shroud. If it is not exactly aligned, you can rotate the magneto slightly until the correct indication is attained. Tighten the mounting hardware securely.

4-26. Spark Plugs

a. Removal.

(1) Use compressed air to blow dirt away from the spark plugs before removing them. This will prevent dirt from entering the cylinders as you remove the spark plugs.

(2) Disconnect the shielded spark plug cables from the spark plugs (44, fig. 4-9) and remove the spark plugs.

b. Cleaning and Inspection.

NOTE

It is normally more economical to replace the spark plugs than for you to clean and regap them. It also provides greater assurance that there are no hidden cracks in the ceramic insulators which could cause engine misfiring at high engine speeds. Cleaning and inspection instructions are given, however, in case it is necessary for you to reuse the removed plugs.

WARNING

Clean all parts in a well-ventilated area. Avoid inhalation of solvent fumes and prolonged exposure of the skin to cleaning solvent. Wash exposed skin thoroughly.

(1) Wipe the exterior of the spark plugs with a cloth dampened with cleaning solvent (fed. spec. P-D-680); dry thoroughly.

(2) Check the ceramic insulators for cracks, porosity, and other damage.

(3) If the electrodes of the spark plugs are not too badly burned, you can remove the scale and other deposits from them. This can be done by a sand-blast-type cleaner or with a contact file. Clean with compressed air to remove any residue.

(4) Inspect the electrodes for severe burning,

cracks, and other damage. If it is necessary to reuse the plugs, correct the contact gap to 0.030 inch.

(5) Replace any spark plugs whose condition is doubtful.

c. Installation.

(1) Make sure all spark plugs are gapped to 0.030 inch before you install them.

(2) Install the spark plugs, using a torque wrench. Tighten the spark plugs to 25 to 30 foot-pounds torque.

(3) Install the shielded spark plug cables on the spark plugs. Make sure the leads are not interchanged. Refer to figure 4-11 to assure proper magneto-to-spark plug wiring.

NO. 1 TERMINAL, UPPER RIGHT HAND, ON MAGNETO END CAP AS SHOWN. OTHER TERMINALS FOLLOW FIRING ORDER IN A CLOCKWISE ROTATION.

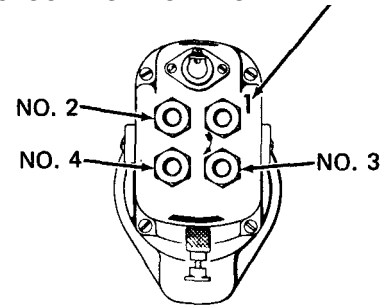

MAGNETO, END CAP VIEW

ME 4320-272-12/4-11

Figure 4-11. Magneto-to-spark plug connections.

4-27. Starting Motor

a. Removal. Remove the starting motor for replacement as follows:

CAUTION

Disconnect the battery cable from the positive battery terminal before disconnecting any other electrical leads from the engine components. This will prevent shorts which could damage the alternator, voltage regulator, and other parts.

(1) Disconnect the electrical lead (2, fig. 4-12) to the starting motor (12) from the starter switch.

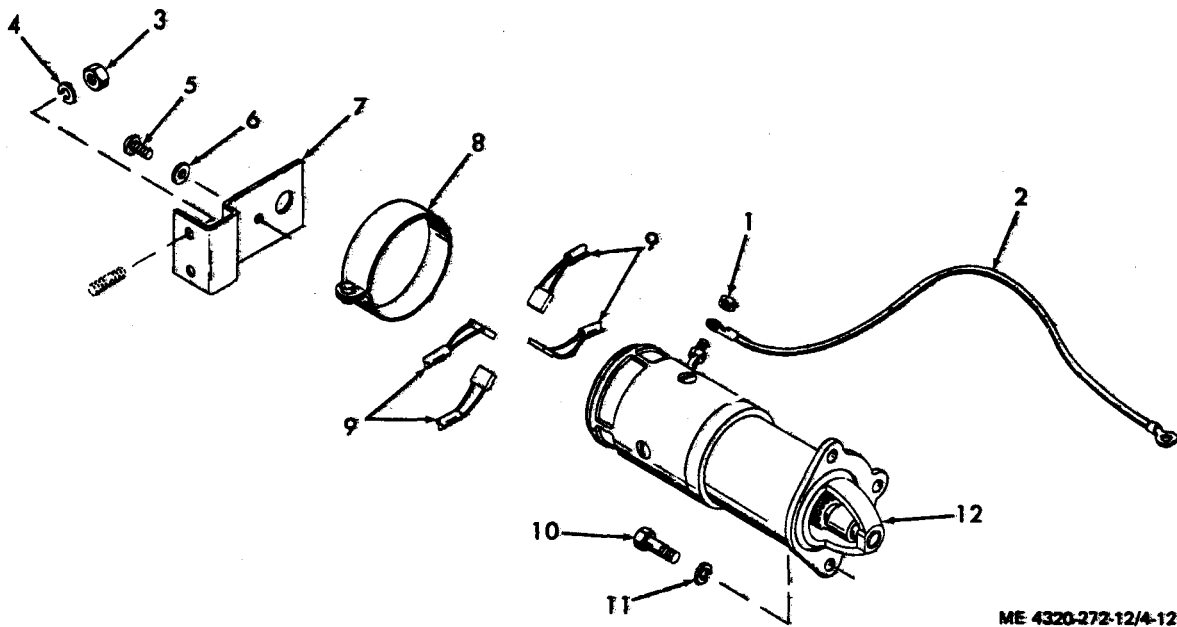

ME 4320-272-12/4-12

- 1. Nut
- 2. Electrical lead
- 3. Nut
- 4. Lock washer
- 5. Screw
- 6. Flat washer

- 7. Support bracket
- 8. Cover band
- 9. Electrical contact brush
- 10. Cap screw
- 11. Lock washer
- 12. Starting motor

Figure 4-12. Starting motor and brush replacement, exploded view.

(2) Remove the nuts (3) and lock washers (4) that secure the support bracket (7) to the engine block.

(3) Remove the screw (5) and flat washer (6) that mount the support bracket (7) to the starting motor; remove the support bracket.

(4) Remove the three cap screws (10) and lock washers (11) that secure the starting motor (12) to the flywheel housing. Pull straight out on the starting motor to remove it from the engine.

b. Cleaning and Inspection.

WARNING

Clean all parts in a well-ventilated area. Avoid inhalation of solvent fumes and prolonged exposure of the skin to cleaning solvent. Wash exposed skin thoroughly.

(1) Clean the exterior of the starting motor with a cloth dampened with cleaning solvent (fed. spec. P-D-680). When you use solvent, take care to prevent it from entering the starting motor.

(2) Inspect the starting motor for cracks, signs of overheating, and other damage.

(3) Inspect the starting motor drive for worn, chipped, and broken gear teeth, and other broken parts.

(4) Remove the brush cover band (8, fig. 4-12) and inspect the starting motor brushes; replace if necessary (subparagraph *c* below).

(5) Replace with a new starting motor if the old motor is damaged in any way.

c. Starter Brush Replacement. If inspection shows you that the brushes are worn less than $\frac{3}{8}$ inch, replace them as follows:

(1) Disconnect the electrical lead (2, fig. 4-12) to the starting motor from the starter switch.

(2) Loosen the cover band screw and slide the cover band (8) from over the brush access openings in the starter frame.

(3) Unhook the spring retaining each brush and hold it out of the way of the brush. Holding the brush by the leads, carefully remove brush through access opening. Remove brush only far enough to disconnect brush leads from field leads. Repeat this procedure with each brush.

NOTE

Before you install the new brushes, check the commutator on the armature shaft. It must be smooth and concentric, free from burrs, scoring, high segments, or other damage. Replace the starting motor if the commutator is damaged.

(4) Install the new brushes in the reverse order of removal. Refer to figure 4-12.

(5) Reinstall the cover band and connect the electrical lead to the starter switch.

4-28. Control Panel Engine Controls and Instruments

a. Removal and Disassembly.

CAUTION

Disconnect the battery cable from the positive battery terminal before disconnecting any leads to the engine

controls and instruments. This will prevent shorts which could damage the alternator, voltage regulator, and other parts.

(1) Disconnect and tag the electrical leads from the engine controls and instruments on the control panel.

(2) Remove and disassemble the engine controls and instruments from the control panel as shown in figure 4-13.

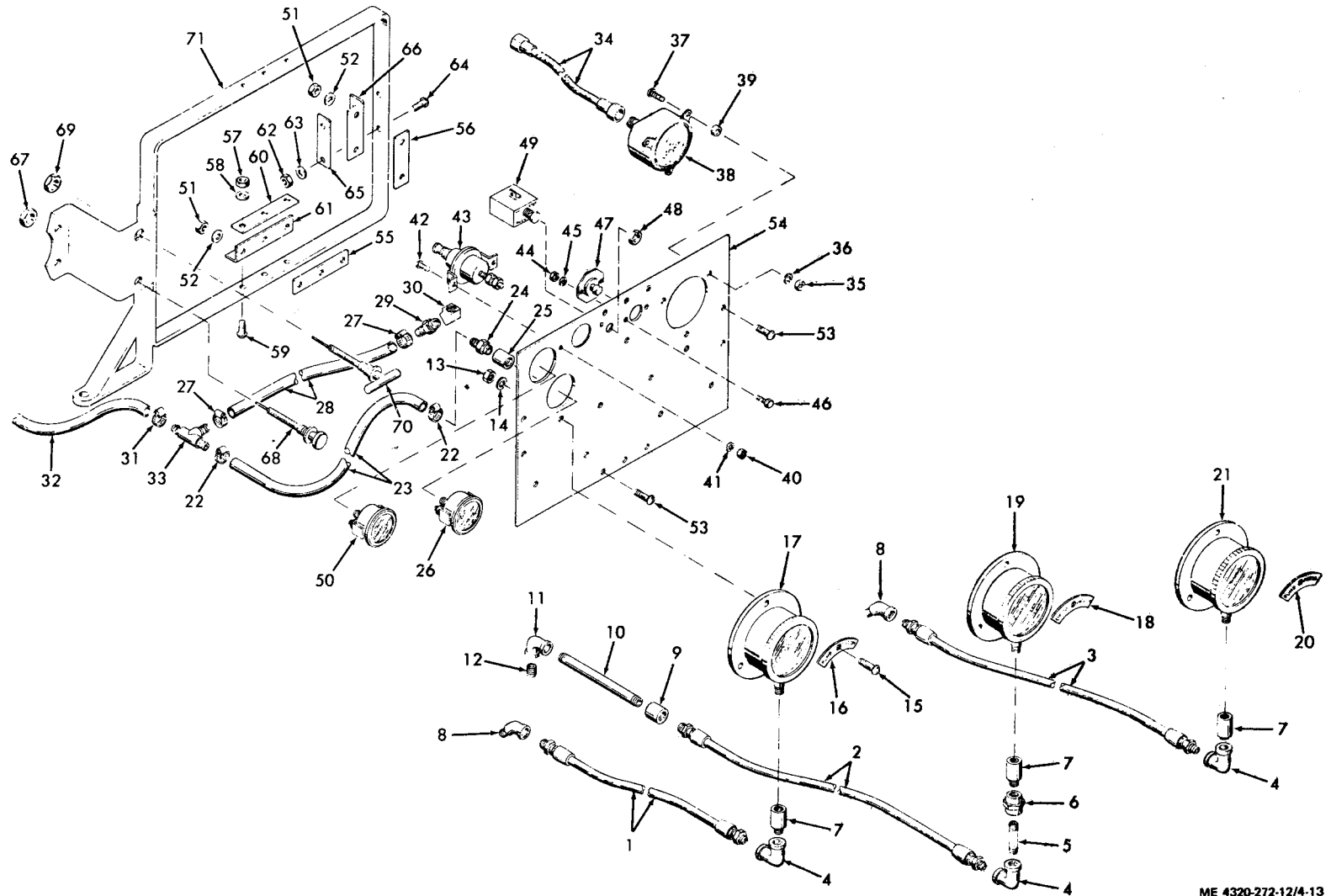

ME 4320-272-12/4-13

Figure 4-13. Control panel and instruments, exploded view

KEY to fig. 4-13:

- | | |
|--------------------------|--------------------------|
| 1. Hose assembly | 37. Screw |
| 2. Hose assembly | 38. Tachometer-hourmeter |
| 3. Hose assembly | 39. Spacer |
| 4. Elbow | 40. Nut |
| 5. Nipple | 41. Lock washer |
| 6. Coupling | 42. Screw |
| 7. Dampener gage | 43. Oil pressure switch |
| 8. Elbow | 44. Nut |
| 9. Coupling | 45. Lock washer |
| 10. Nipple | 46. Cap screw |
| 11. Elbow | 47. Starter switch |
| 12. Nipple | 48. Nut |
| 13. Nut | 49. Magneto stop switch |
| 14. Lock washer | 50. Ammeter |
| 15. Screw | 51. Nut |
| 16. Nameplate | 52. Flat washer |
| 17. Suction gage | 53. Screw |
| 18. Nameplate | 54. Panel |
| 19. Engine vacuum gage | 55. Mounting plate |
| 20. Nameplate | 56. Mounting plate |
| 21. Pressure gage | 57. Nut |
| 22. Hose clamp | 58. Flat washer |
| 23. Hose | 59. Screw |
| 24. Hose fitting | 60. Mounting plate |
| 25. Coupling | 61. Flexible mounting |
| 26. Oil pressure gage | 62. Nut |
| 27. Hose clamp | 63. Flat washer |
| 28. Hose | 64. Screw |
| 29. Hose fitting | 65. Mounting plate |
| 30. Elbow | 66. Flexible mounting |
| 31. Hose clamp | 67. Nut |
| 32. Hose | 68. Choke control |
| 33. Hose fitting | 69. Nut |
| 34. Flexible drive shaft | 70. Throttle control |
| 35. Nut | 71. Panel bracket |
| 36. Lock washer | |

b. Cleaning and Inspection.

WARNING

Clean all parts in a well-ventilated area. Avoid inhalation of solvent fumes and prolonged exposure of the skin to cleaning solvent. Wash exposed skin thoroughly.

(1) Clean all parts by wiping them with a cloth dampened lightly with cleaning solvent (fed. spec. P-D-680). You must be careful to prevent the solvent from entering the interior of the components.

(2) Inspect all meters and gages for cracked dial glass, defaced or illegible dial marking, sticking

or binding dial pointers, damaged terminals, evidence of entry of moisture, and other damage. Replace damaged gages and meters.

(3) Check all switches for cracked cases, difficult operation, lack of positive switch action, and other damage. When you check the switches for continuity, use a multimeter or test lamp. Replace defective switches.

(4) Inspect the magneto stop switch for cracks, loose or damaged terminals, and other damage. Continuity should not exist when the switch is in the run position; continuity should exist when the switch is in the stop position. Replace a damaged or inoperative magneto switch.

(5) Inspect the hoses for cuts, abrasions, leaks, damaged threads, and other damage. Replace damaged hoses.

(6) Check the operation of the oil pressure safety switch by checking continuity across the terminals while you apply air pressure to the pressure port. Start with the switch in the reset position (with the spring clip inserted under the recess in the housing). No continuity must exist at this time. Slowly apply air pressure. When approximately 1½ psi pressure is applied, the spring clip must disengage from the housing, with no continuity being maintained through the switch. Increase pressure to maximum 5 psi, then reduce pressure. When you lower pressure to approximately 1 psi, continuity must be established and must remain when the pressure is further reduced to zero. Replace the switch if it fails to perform as indicated.

(7) Inspect all other parts for cracks, distortion, damaged threads, and other damage; replace damaged parts.

c. Reassembly and Installation.

(1) Reassemble and install the controls, indicators, and gages in the opposite order of removal; refer to figure 4-13.

(2) Connect the electrical leads to the properly tagged components. Refer to figure 1-3, wiring diagram.

(3) After installation, start the engine and check that you have proper operation of switches and gages. Check thoroughly for leaks.

Section X. MAINTENANCE OF NON-ELECTRICAL GAGES

4-29. Description

a. Three large gages on the engine control panel keep you informed of the pump suction and discharge pressures, and the engine vacuum. They are connected to their related system by hoses and fittings. Each system incorporates a dampener at

each gage to prevent momentary pressure surges from damaging the related gage.

b. The tachometer-hourmeter mounted on the control panel is driven by a flexible drive shaft which connects to a drive adapter on the governor.

The drive adapter provides the rotational force necessary to operate the tachometer-hourmeter.

4-30. Suction, Discharge, and Vacuum Gages, Lines, and Fittings

a. Removal and Disassembly.

(1) Remove and disassemble the lines and fittings from the gages and from the pump as shown in figure 4-13.

(2) Remove the screws (15), nuts (13), and lock washers (14) that secure the gages (17, 19, and 21) and nameplates (16, 18, and 20) to the control panel; remove the gages.

b. Cleaning and Inspection.

WARNING

Clean all parts in a well-ventilated area. Avoid inhalation of solvent fumes and prolonged exposure of the skin to cleaning solvent. Wash exposed skin thoroughly.

(1) Clean the suction, discharge, and vacuum gages with a cloth dampened with cleaning solvent (fed. spec. P-D-680); dry thoroughly.

(2) Clean all lines and fittings by washing in cleaning solvent. Shake off excessive solvent. Blow through the lines with compressed air to make sure they are clear.

(3) Inspect the gages for cracked dial glass, binding or sticking needle movement, illegible dial faces, evidence of water entry, and other damage. If possible, check the operation against master gages to assure the accuracy of the indications. Replace damaged gages.

(4) Inspect the hoses for cuts, abrasions, leaks, damaged threads, and other damage; replace damaged hoses.

(5) Inspect all other parts for cracks, distortion, damaged threads, and other damage; replace damaged parts.

c. Reassembly and Installation. Install the

suction, discharge, and vacuum gages, lines, and fittings as shown in figure 4-13. After assembly, start the pump and check for leaks. Correct leaks before restoring the pumping assembly to service.

4-31. Tachometer-Hourmeter and Tachometer Drive

a. Removal.

(1) Disconnect the flexible drive shaft (34, fig. 4-13) from both the tachometer-hourmeter (38) and from the tachometer drive adapter on the governor.

(2) Remove the tachometer-hourmeter from the control panel by removing screws (37), spacers (39), nuts (35), and lock washers (36).

b. Cleaning and Inspection.

WARNING

Clean all parts in a well-ventilated area. Avoid inhalation of solvent fumes and prolonged exposure of the skin to cleaning solvent. Wash exposed skin thoroughly.

(1) Wipe the exterior of the tachometer-hourmeter and the flexible shaft with a cloth dampened with cleaning solvent (fed. spec. P-D-680).

(2) Inspect the tachometer for broken dial glass, defaced or illegible dial markings, binding or sticking pointer, jammed digital hour counter, or evidence of entry of moisture. Replace a damaged tachometer-hourmeter.

(3) Inspect the tachometer shaft for kinks, broken sheathing, binding or catching rotation of the internal shaft, and damaged threads on the coupling nuts. Replace a damaged tachometer shaft.

c. Installation. Installation is the reverse of removal; refer to figure 4-13. After installation, start the engine and check the tachometer for proper operation.

Section XI. MAINTENANCE OF ENGINE

4-32. Description

The only maintenance you will be concerned with at the organizational maintenance level is servicing the intake and exhaust manifold, and checking the engine cylinder compression. The manifold is mounted on top of the cylinder blocks and the carburetor mounts to the manifold. The manifold serves both intake and exhaust systems.

4-33. Intake and Exhaust Manifold

a. Removal.

(1) Remove the exhaust system parts (para 4-15).

(2) Remove the air cleaner piping (para 4-17).

(3) Remove the carburetor (para 4-20).

(4) Remove and disassemble the manifold as shown in figure 4-7.

b. Cleaning and Inspection.

(1) Discard and replace all gaskets.

WARNING

Clean all parts in a well-ventilated area. Avoid inhalation of solvent fumes and prolonged exposure of the skin to cleaning solvent. Wash exposed skin thoroughly.

(2) Clean the manifold with a wire brush. You remove greasy or gummy deposits with cleaning solvent (fed. spec. P-D-680).

(3) Inspect the manifold for cracks, distortion, broken mounting flanges, damaged threads, and other damage; replace a damaged manifold.

(4) Inspect the manifold gasket inserts for cracks, distortion, and other damage. Replace broken or damaged inserts.

(5) Inspect remaining parts for cracks, distortions, damaged threads, and other damage; replace damaged parts.

c. Reassembly and Installation.

(1) Reassembly and installation is the reverse of disassembly. Use new gaskets. Refer to figure 4-7. When you tighten the manifold mounting nuts (5), torque them to 35 foot-pounds.

2) Install the carburetor (para 4-20).

3) Install the air cleaner piping (para 4-17).

4) Install the exhaust system parts (para 4-15).

(5) After the engine has been run at operating temperature and has cooled, recheck the torque of

the mounting nuts. If necessary, retighten them to 35 foot-pounds torque.

4-34. Checking Engine Compression

a. Low or uneven cylinder compression can cause the engine to run erratically, misfire, or even fail to start. If the engine has proper compression, you will encounter considerable resistance in the pull on the starting crank. If resistance is not encountered, compression is faulty.

b. The compression may be weak on an engine which has been out of operation for some time, for the oil may have drained off the cylinder. You may restore compression by removing the spark plugs and pouring about 1 fluid ounce of oil into each cylinder.

c. Check each of the cylinders for uneven compression with a compression pressure gage. If one or more cylinders indicate obviously lower compression, report the trouble to direct support maintenance.

Section XII. MAINTENANCE OF WHEELS

4-35. Description

a. The tire assembly includes the tire and inner tube. The tire size is 7.00-15, 8-ply rating, with a regular tread. The tires are mounted on single-piece wheels, and must be inflated to 60 psi.

b. The wheel assemblies consist of pressed steel wheels which are bolted to the hub assemblies. The

hub assemblies ride on tapered roller bearings on axle spindles.

4-36. Tires and Tubes

a. Removal. Deflate the inner tube. Use proper tire removal tools to remove the tire and tube from the wheel, as indicated in figure 4-14.

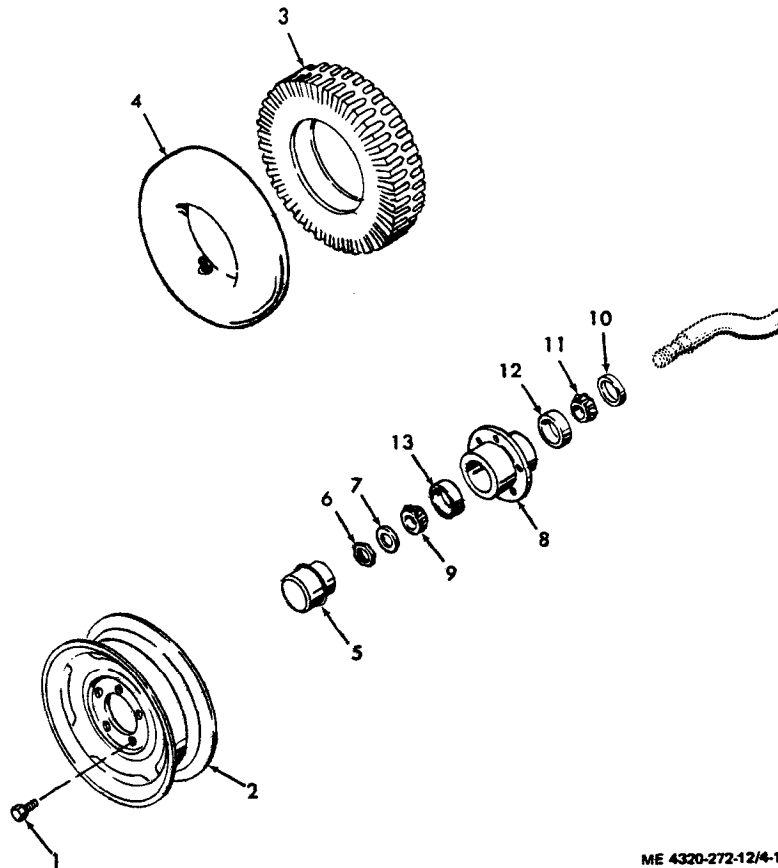

ME 4320-272-12/4-14

1. Cap screw
2. Wheel
3. Tire
4. Inner tube
5. Grease cup
6. Nut
7. Washer

8. Hub
9. Bearing cone
10. Oil seal
11. Bearing cone
12. Bearing cup
13. Bearing cup

Figure 4-14. Wheel assembly, exploded view.

b. Cleaning and Inspection.

(1) Clean the tires with a high-pressure water hose.

(2) Inspect the tire for cuts, bruises, punctures, worn treads, imbedded stones, and severe abrasions. Skive around cuts and imbedded stones with a sharp knife to remove all edges which could catch against sharp rocks and result in further tearing. Inspect the inside of the tire for broken cords and punctured walls. Replace tires which are damaged beyond repair.

(3) You can check the inner tube by filling it with air and immersing it in water to locate any leaks. Patch the leaks. Check the tube for cracks, brittleness, and signs of deterioration. Replace defective tubes.

c. Installation. Using proper tire mounting tools, install the tires and tubes on the wheel as shown in figure 4-14. Note the following:

(1) Position the inner tube (4) in the tire (3).

(2) Position the assembled tire and tube on the wheel (2), making sure the valve stem extends in the required direction.

(3) After you have properly mounted the tire on the wheel, inflate the tire to 60 psi.

4-37. Wheel and Hub Assembly

a. Removal and Disassembly. Remove and disassemble the wheel and hub assembly as shown in figure 4-14. Note the following:

(1) If the tires leak or if they are damaged, you should service them as directed above. If they

do not require servicing, they can remain on the wheels.

(2) Do not remove the bearing cups (12 and 13) from the hub (8) unless you plan to replace the bearing cones (9 and 11). The bearings must be replaced as sets.

b. Cleaning and Inspection.

(1) Discard all gaskets and seals.

WARNING

Clean all parts in a well-ventilated area. Avoid inhalation of solvent fumes and prolonged exposure of the skin to cleaning solvent. Wash exposed skin thoroughly.

(2) Clean the bearing cones by placing them in a wire basket and agitating them in a container of cleaning solvent (fed. spec. P-D-680). After you clean the bearings, dip them in light oil and wrap in lint-free paper to prevent entry of dirt and grit.

(3) Clean all other parts with dry cleaning solvent; dry thoroughly.

(4) Inspect the wheel for cracks, distortion, burrs on bead rim, and other damage. Remove all burrs with a file or fine stone. Replace damaged wheels.

(5) Inspect the bearing cones for rough, scored, or brinnelled rollers, scored races, and bent cages. Inspect the bearing cups for wear and scoring. If either the cone or cup of a bearing set is damaged, you must replace both parts.

c. Reassembly and Installation. Reassembly and installation is essentially the reverse of the disassembly sequence; refer to figure 4-14. Use new seals for reassembly. Before installing the wheel bearings you should service them as follows:

(1) Pack wheel bearings with grease before installing them in the hub. Refer to LO 5-4320-272-12.

(2) As you reassemble the hub assembly, adjust the wheel bearings as follows:

(a) With the wheel and tire installed on the hub, tighten the nut (6) while rotating the wheel and tire until a distinct drag is felt.

(b) Continue to rotate the wheel and tire and back off the nut just enough to release the drag on the wheel. Bend tang on washer (7) to lock the nut (6) in position.

Section XIII. MAINTENANCE OF ACCESSORY ITEMS

4-38. Description

a. The fire extinguisher is installed in a bracket at the left front of the unit.

b. The tool box is mounted on the left front of the pump frame.

c. Four reflectors are mounted on the pump

frame. Red reflectors are mounted at the rear and amber reflectors are mounted at the front.

4-39. Accessory Items

a. Removal.

(1) Remove the fire extinguisher and bracket (items 1 thru 6, fig. 4-15).

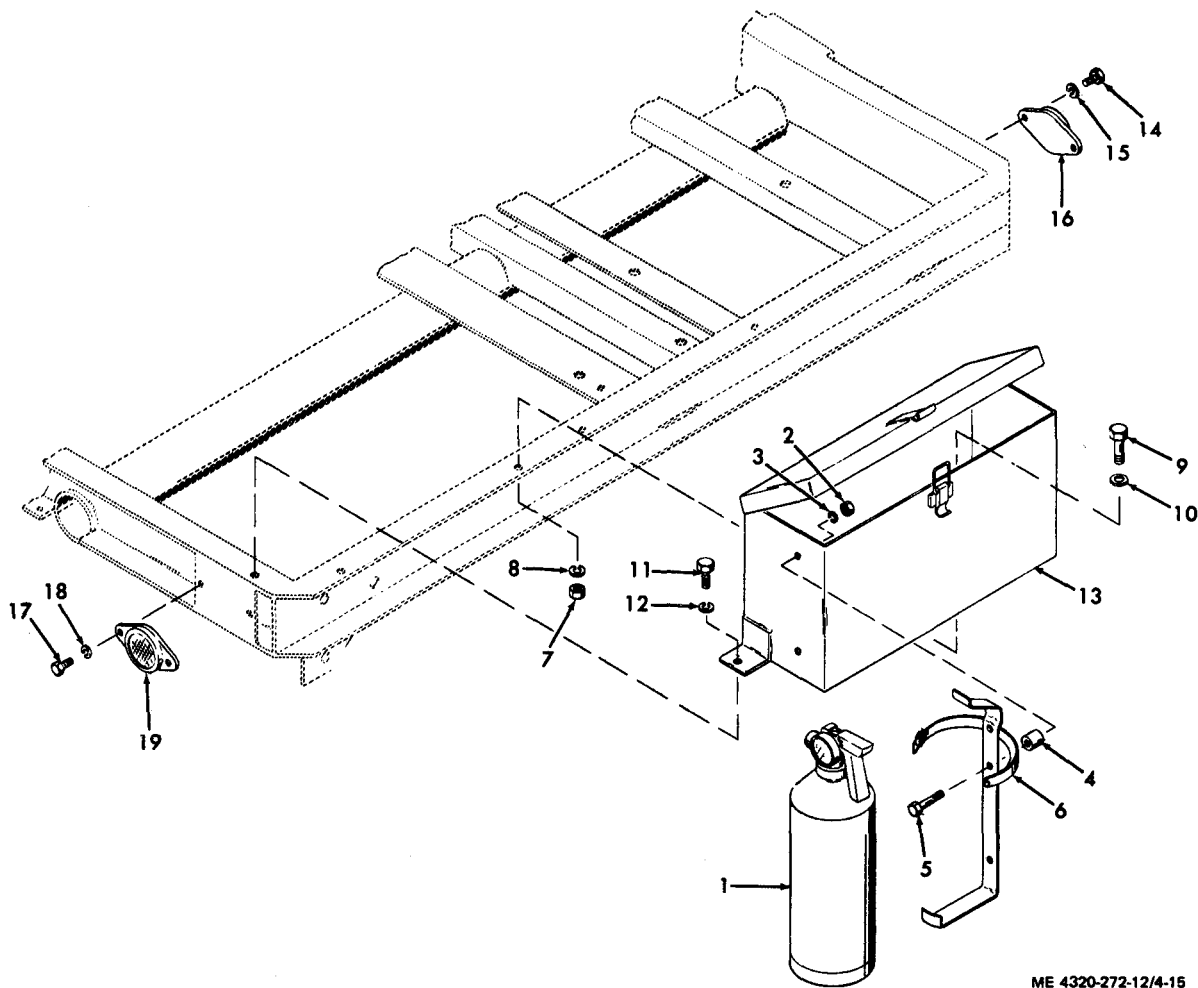

- | | |
|-------------------------|-----------------|
| 1. Fire extinguisher | 11. Cap screw |
| 2. Nut | 12. Leek washer |
| 3. Lock washer | 13. Tool box |
| 4. Spacer | 14. Cap screw |
| 5. Cap screw | 15. Lock washer |
| 6. Extinguisher bracket | 16. Reflector |
| 7. Nut | 17. Cap screw |
| 8. Lock washer | 18. Lock washer |
| 9. Cap screw | 19. Reflector |
| 10. Washer | |

Figure 4-15. Accessory items, exploded view.

(2) Remove the tool box and related parts (items 7 thru 13).

(3) Remove the reflectors and related parts (items 14 thru 19).

b. Cleaning and Inspection.

WARNING

Clean all parts in a well-ventilated area. Avoid inhalation of solvent fumes and prolonged exposure of the skin to cleaning solvent. Wash exposed skin thoroughly.

(1) Clean the fire extinguisher and bracket with a cloth dampened with cleaning solvent (fed. spec. P-D-680).

(2) Flush the tool box with water. Remove greasy and gummy deposits with cleaning solvent (fed. spec. P-D-680).

(3) Clean reflectors with a damp cloth.

(4) Inspect the fire extinguisher for damaged operating parts, leaks, and illegible instructions. Check for full charge. Replace a damaged or spent fire extinguisher.

(5) Inspect the tool box for cracks, dents, severe rust, and other damage. You can remove minor rust with fine sandpaper. Refinish all areas requiring it. Replace a damaged tool box.

(6) Inspect the reflectors for cracks and

damage; replace damaged reflectors.

c. Reassembly. Reassemble and install the fire extinguisher, tool box, and reflectors as shown in figure 4-15.

Section XIV. MAINTENANCE OF PUMP

4-40. Description

a. Suction Piping and Strainer. The suction system of the pump has dual, four-inch gate valves connected to a suction manifold. A strainer is connected between the suction manifold and the pump to remove solid materials from the fluid being pumped. The suction system is provided with female quick-disconnect fittings to facilitate your connection of the intake hoses.

b. Discharge Piping. The discharge piping system of the centrifugal pump has two discharge valves connected to a discharge manifold. Between the discharge manifold and the pump are a lever-operated check valve and an air eliminator. The check valve prevents reverse flow of fluid through the pump. If desired, you can override the normal check valve operation. The air eliminator expels air from the pump during priming cycle.

c. Gate Value. Suction and discharge gate valves are identical. When you rotate the valve handwheel to open the valve, the valve disc assembly is raised from the valve seat to allow fluid flow. When you rotate the handwheel to close the valve, the stem first lowers the disc assembly into alignment with the valve seat and then expands the parts of the disc assembly outward to seal the fluid flow through the valve.

d. Check Value. The check valve is mounted in the discharge line to prevent the reverse flow of

fluid through the pump by closing automatically at shutdown. This is the normal mode of operation. However, if you want the check valve to remain open at shutdown so that the discharge lines drain back to the fuel source (provided that the discharge lines are higher than the pump inlet), you can adjust the valve to provide this type of operation.

e. Air Eliminator. The air eliminator assembly is provided in the discharge line to expel the air during the priming cycle. It consists primarily of a float-operated valve that remains open until the liquid in the air eliminator body reaches a level high enough to buoy up the float and close the valve. Prior to this time the air in the housing is allowed to escape through the valve. The closing of the valve prevents the liquid from discharging through the valve.

4-41. Suction Piping and Strainer

a. Removal and Disassembly.

(1) Make sure the piping is drained of all fluid and intake hoses are disconnected before you begin to disassemble the piping.

(2) Disconnect the pump suction gage hose from the strainer housing.

(3) Service the suction strainer (para 3-12).

(4) Disassemble the suction piping as shown in figure 4-16.

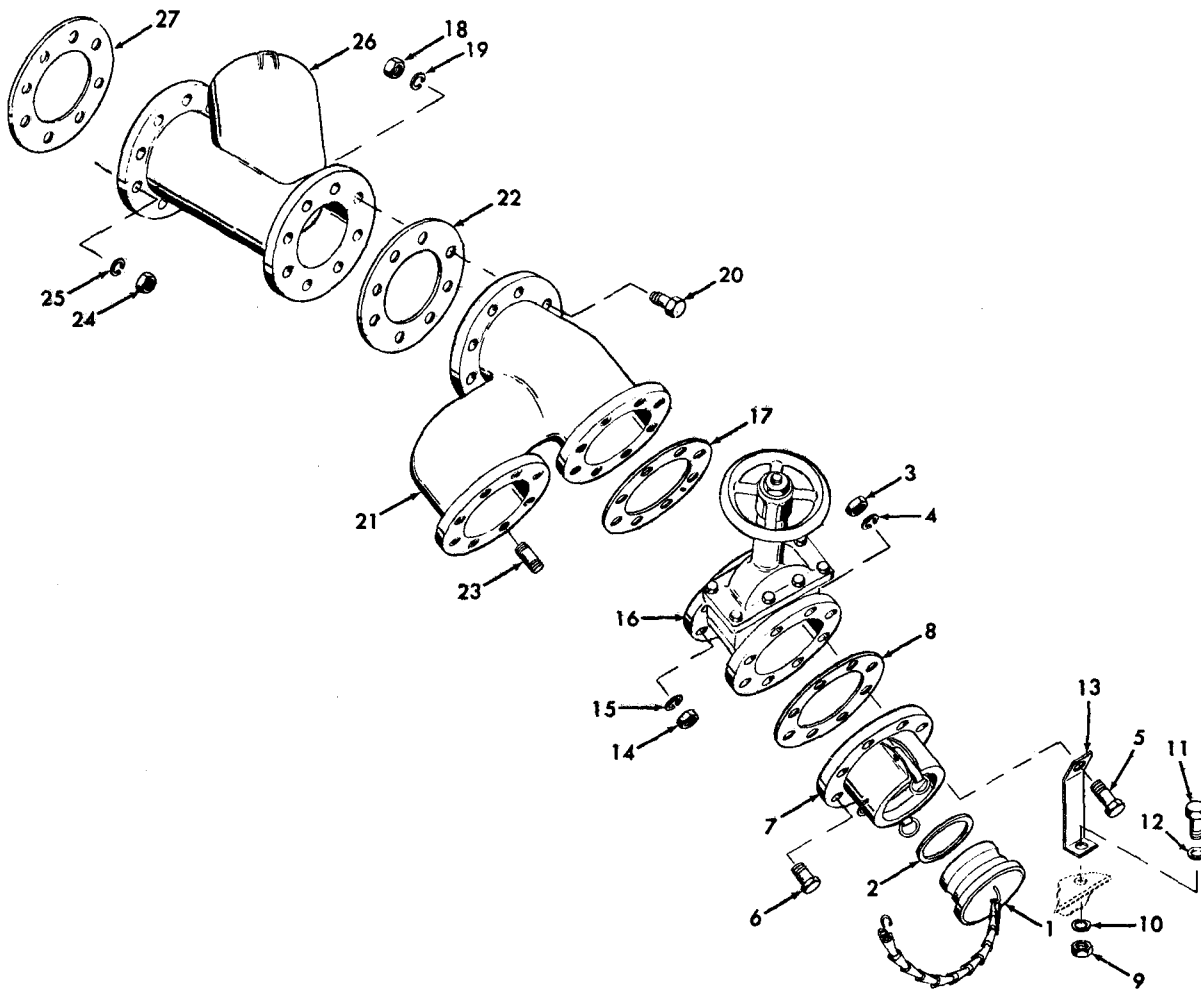

ME 4320-272-12/4-16

- | | |
|-----------------|----------------------|
| 1. Dust plug | 15. Lock washer |
| 2. Gasket | 16. Gate valve |
| 3. Nut | 17. Gasket |
| 4. Lock washer | 18. Nut |
| 5. Cap screw | 19. Lock washer |
| 6. Cap screw | 20. Cap screw |
| 7. Coupling | 21. Manifold |
| 8. Gasket | 22. Gasket |
| 9. Nut | 23. Stud |
| 10. Lock washer | 24. Nut |
| 11. Cap screw | 25. Lock washer |
| 12. Flat washer | 26. Strainer housing |
| 14. Nut | 27. Gasket |

Figure 4-16. Suction piping assembly, exploded view.

b. *Cleaning and Inspection.* Clean and inspect the parts after you disassemble them, as follows:

(1) Discard and replace all gaskets. Clean all remaining parts with cleaning solvent. You can use a soft-bristled brush on the strainer basket if necessary to remove clogging.

(2) Inspect the gate valves (16) for cracks and

damaged flanges. Operate the valve handwheel to check for free operation. Refer to paragraph 4-43 for valve repair instructions.

(3) Inspect all other piping parts for cracks and damaged flanges. Inspect the suction manifold (21) for damaged studs (23). Replace as necessary. If you find that the stud mounting holes in the

manifold are damaged, you must replace the entire manifold.

(4) Replace all damaged or defective parts.

(5) Touch up or repaint all areas requiring it.

c. Reassembly and Installation. Using all new gaskets, reassemble the suction piping in the reverse order of disassembly; refer to figure 4-16. After reassembly, start and operate the centrifugal pump and check for leaks. Correct any deficiencies.

4-42. Discharge Piping

a. Removal and Disassembly.

(1) Make sure the piping is drained of all fluid

and discharge hoses are disconnected before you begin to disassemble the piping.

(2) Disconnect the pump pressure gage hose from the air eliminator housing.

(3) If the gages and instruments are connected to the control panel, make sure you properly support the panel when removing it from the piping to avoid damaging the instrument leads and cables.

(4) Disassemble the discharge piping as shown in figure 4-17.

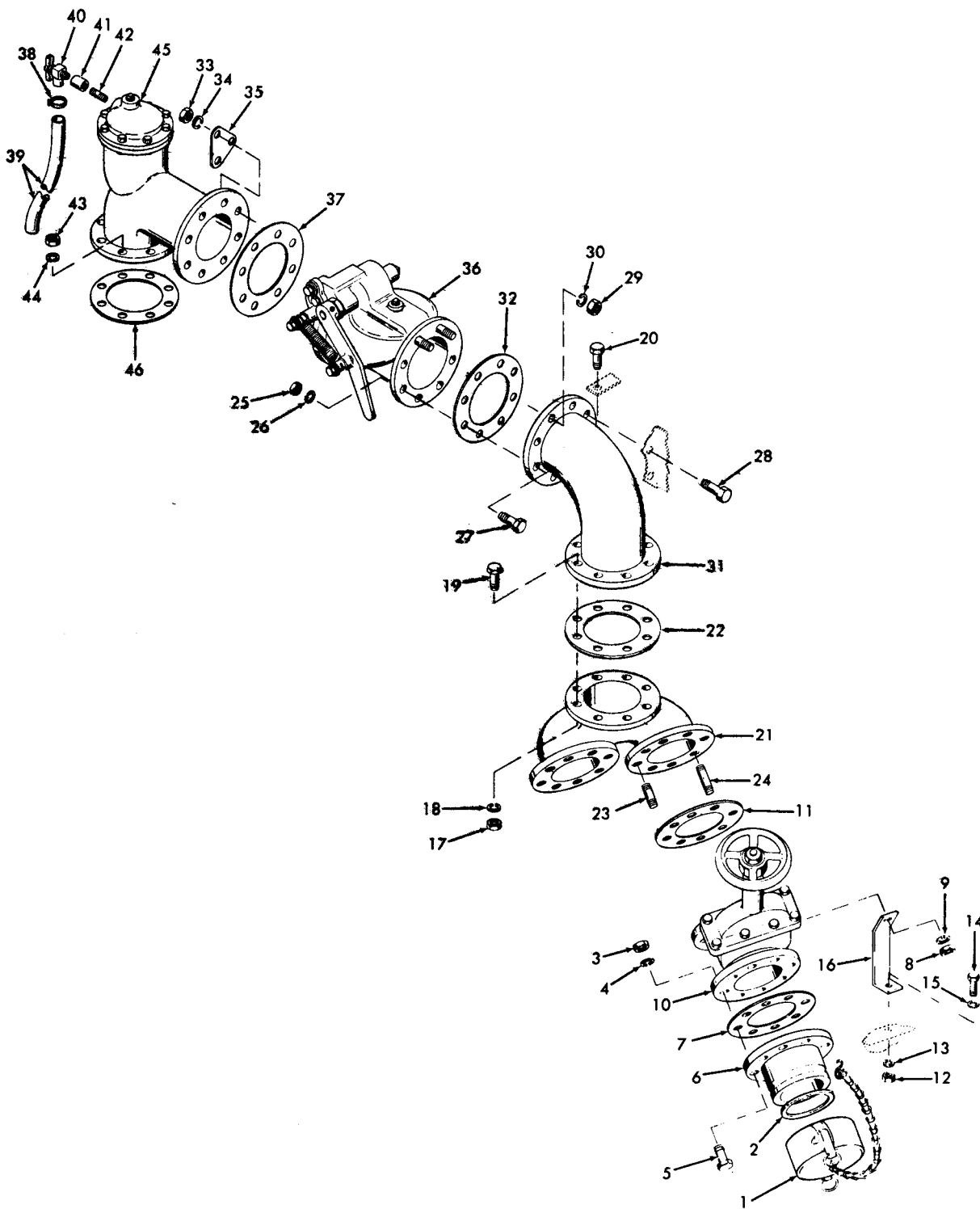

ME 4320-272-12/4-17

Figure 4-17. Discharge piping assembly, exploded view.

KEY to fig. 4-17:

- | | |
|-----------------|--------------------|
| 1. Dust cap | 24. Stud |
| 2. Gasket | 25. Nut |
| 3. Nut | 26. Lock washer |
| 4. Lock washer | 27. Cap screw |
| 5. Cap screw | 28. Cap screw |
| 6. Coupling | 29. Nut |
| 7. Gasket | 30. Lock washer |
| 8. Nut | 31. Elbow |
| 9. Lock washer | 32. Gasket |
| 10. Gate valve | 33. Nut |
| 11. Gasket | 34. Lock washer |
| 12. Nut | 35. Cable bracket |
| 13. Lock washer | 36. Check valve |
| 14. Cap screw | 37. Gasket |
| 15. Flat washer | 38. Hose clamp |
| 16. Bracket | 39. Hose |
| 17. Nut | 40. Drain cock |
| 18. Lock washer | 41. Coupling |
| 19. Cap screw | 42. Nipple |
| 20. Cap screw | 43. Nut |
| 21. Manifold | 44. Lock washer |
| 22. Gasket | 45. Air eliminator |
| 23. Stud | 46. Gasket |

b. Cleaning and Inspection.

(1) Discard and replace all gaskets. Clean all remaining parts with cleaning solvent (fed. spec. P-D-680); dry thoroughly.

(2) Inspect the gate valve (10, fig. 4-17) for cracks and damaged flanges. Operate the valve handwheel to check for free operation. Refer to paragraph 4-43 for valve repair instructions.

(3) Inspect the check valve (36) for cracks, loose studs, and other apparent damage. Check the lever for free operation. If the check valve operates improperly or is damaged, you can repair valve as described in paragraph 4-44.

(4) Inspect the air eliminator assembly (45) for cracks and other damage. If damaged, repair it as described in paragraph 4-45.

(5) Inspect all other piping parts for cracks and for damaged flanges. Inspect the discharge manifold (21) for damaged studs (23 and 24). Replace as necessary. If stud mounting holes in the manifold are damaged, replace the entire manifold.

- (6) Replace all defective parts,
- (7) Touch up or repaint all areas requiring it.

c. Reassembly and Installation.

(1) Using all new gaskets, reassemble the discharge piping in the reverse order of disassembly; refer to figure 4-17.

(2) After you reassemble the piping, start and operate the centrifugal pump and check for leaks. Correct any deficiencies.

4-43. Gate Valve

a. Removal and Disassembly.

(1) Remove the gate valve as indicated in either figure 4-16 or figure 4-17.

(2) Disassemble the gate valve following the sequence of the index numbers in the exploded view

in figure 4-18. You should not attempt to remove the seat rings from the valve body.

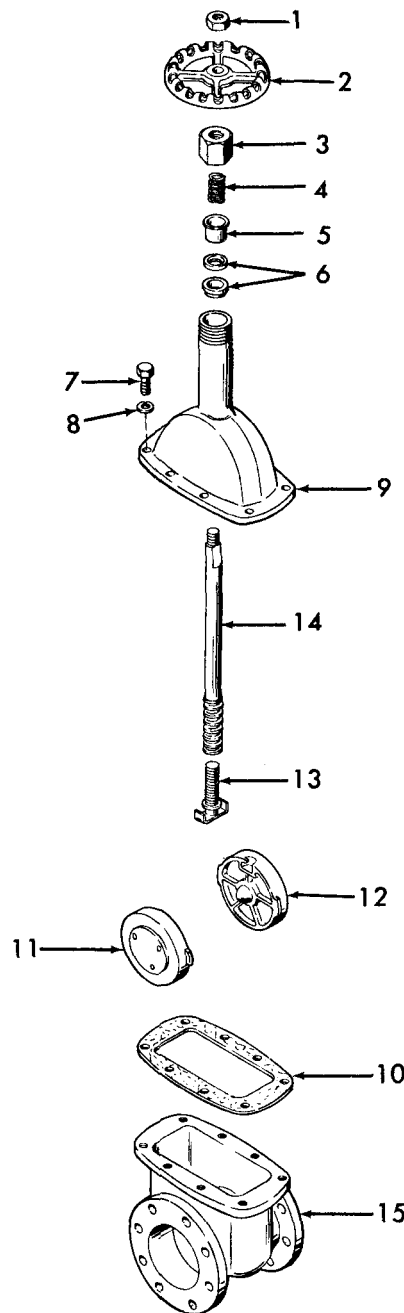

ME 4320-272-12/4-18

- | | |
|----------------|-----------------|
| 1. Nut | 9. Bonnet |
| 2. Handwheel | 10. Gasket |
| 3. Packing nut | 11. Female disc |
| 4. Spring | 12. Male disc |
| 5. Retainer | 13. Disc stem |
| 6. Packing set | 14. Valve stem |
| 7. Cap screw | 15. Body |
| 8. Lock washer | |

Figure 4-18. Gate valve, exploded view.

b. Cleaning and Inspection.

- (1) Discard and replace the valve packing set (6, fig. 4-18) and the gasket (10).

WARNING

Clean all parts in a well-ventilated area. Avoid inhalation of solvent fumes and prolonged exposure of the skin to cleaning solvent. Wash exposed skin thoroughly.

- (2) Clean all remaining parts with cleaning solvent (fed. spec. P-D-680); dry thoroughly with compressed air.

- (3) Inspect the valve bonnet (9) and body (15) for cracks, damaged threads and flanges. Inspect the stem threads of the bonnet for wear and damage. Inspect the seat rings in the body. You can repair minor damage to seat rings with a fine emery cloth. You must remove stock evenly to prevent leaking.

- (4) Inspect the disc stem (13) and valve stem (14) for distortion and damaged threads.

- (5) Inspect the female disc (11) and male disc (12) for cracks and for scoring of the seating area. Replace damaged parts.

- (6) Replace all parts damaged beyond repair.

c. Reassembly and Installation.

- (1) Reassemble the gate valve in the reverse order of disassembly. Refer to figure 4-18.

- (2) Install the gate valve according to either figure 4-16 or 4-17.

- (3) After reassembly and installation, start the centrifugal pump and check for leaks. Correct any leaks before you restore the pumping assembly to service.

4-44. Check Valve

a. Adjustment. You can adjust the check valve for manual or automatic closing as follows:

- (1) Loosen cap screws (10 and 11, fig. 4-19) to permit spring bracket (14) adjustment.

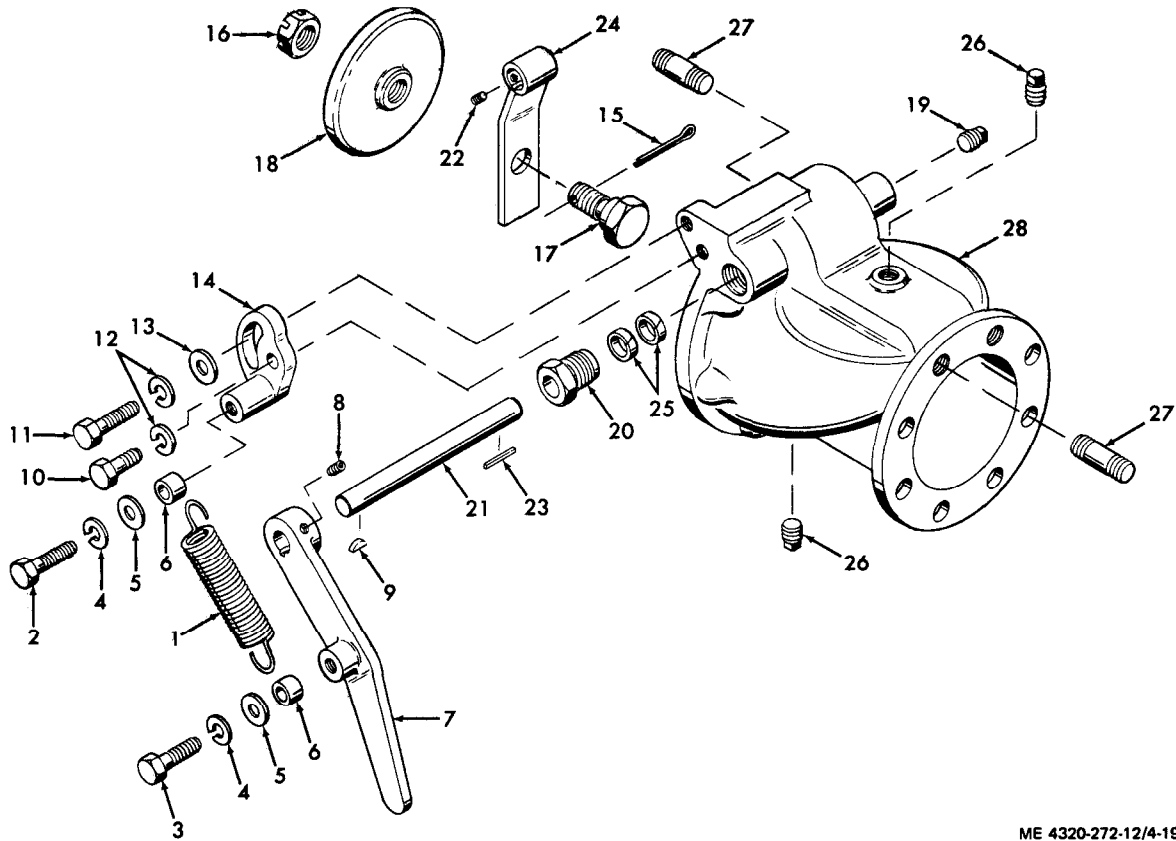

ME 4320-272-12/4-19

1. Spring
2. Cap screw
3. Cap screw
4. Lock washer
5. Flat washer
6. Spacer
7. Handle

8. Setscrew
9. Key
10. Cap screw
11. Cap screw
12. Lock washer
13. Flat washer
14. Spring bracket

15. Cotter pin
16. Nut
17. Shoulder bolt
18. Valve disc
19. Pipe plug
20. Packing nut
21. Shaft

22. Setscrew
23. Key
24. Valve arm
25. Packing ring
26. Pipe plug
27. Stud
28. Body

Figure 4-19. Check valve, exploded view.

(2) To adjust the check valve for automatic closing, rotate the spring bracket (14) counterclockwise so that the spring pulls the check valve closed after you operate the lever manually to fully open the valve.

(3) To adjust the check valve so that it remains open when set, rotate the spring bracket (14) clockwise so that an overcentering action occurs as the valve is fully opened, requiring manual pressure on the lever to close it.

(4) After you have made the required adjustment, tighten the cap screws (10 and 11) to lock the spring bracket in position.

b. Removal and Disassembly. Remove the check valve as indicated in paragraph 4-42. Disassemble the check valve following the sequence of index numbers assigned to the exploded view in figure 4-19. Note the following:

(1) To remove the valve shaft (21), you must remove the setscrews (22) and the packing nut (20), and insert a soft drift through the hole from which the plug (19) was removed. Tap on the end of the drift to dislodge the shaft.

(2) You will have to use a pointed or hooked instrument to dislodge the packing rings (25) from the body (28).

(3) Do not remove the stud (27) from the valve body (28) unless they are damaged or loose.

c. Cleaning and Inspection.

WARNING

Clean all parts in a well-ventilated area. Avoid inhalation of solvent fumes and prolonged exposure of the skin to cleaning solvent. Wash exposed skin thoroughly.

(1) Discard and replace the packing rings (25). Clean all remaining parts with cleaning solvent (fed. spec. P-D-680); dry thoroughly.

(2) Inspect the valve disc (8) for cracks, distortion, or other damage. You can remove minor burrs on the seating surface with fine emery cloth.

(3) Inspect valve body (28) for cracks, damaged threads, damaged flanges, worn shaft bore, and damaged seating surface. You can remove minor nicks or burrs from the valve seats if necessary. Clean up the seats evenly so that they permit proper seating of the valve discs.

(4) Inspect the shaft (21) for wear of the bearing surfaces. Replace if you see any indications of wear.

(5) Inspect all other parts for cracks, distortion, and damaged threads; replace any damaged parts.

d. Reassembly and Installation. Reassembly and installation is essentially the reverse of the disassembly and removal sequence. Refer to figure 4-19 and 4-17. Pay particular attention to the following:

(1) Use new packing rings (25, fig. 4-19)

when you reassemble the valve. Tighten the packing nut tightly enough to prevent leaking, but not so tightly that it prevents free rotation of the shaft.

(2) Adjust the check valve for automatic closing or for manual closing as directed in subparagraph *a* above.

(3) After you install the valve, start the pump and check that the valve opens and closes properly and that there are no leaks. Correct any deficiencies.

4-45. Air Eliminator

a. Removal and Disassembly. Remove the air eliminator from the discharge piping assembly as described in paragraph 4-42. Disassemble the air eliminator following the sequence of index numbers assigned to the exploded view in figure 4-20.

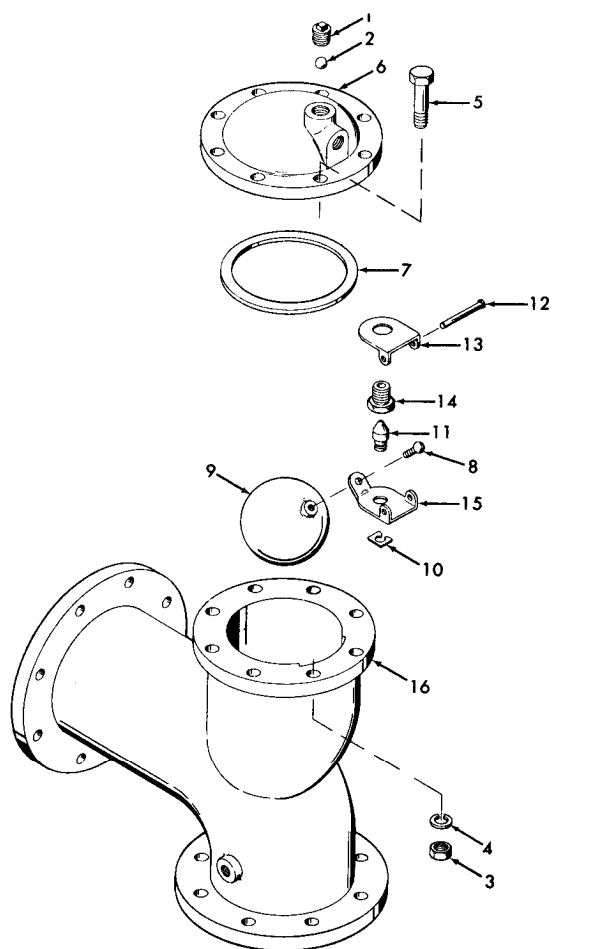

ME 4320-272-12/4-20

- | | |
|----------------|----------------|
| 1. Pipe plug | 9. Float |
| 2. Ball | 10. Retainer |
| 3. Nut | 11. Valve seat |
| 4. Lock washer | 12. Pin |
| 5. Cap screw | 13. Clip |
| 6. Cover | 14. Valve seat |
| 7. Gasket | 15. Lever |
| 8. Screw | 16. Body |

Figure 4-20. Air eliminator, exploded view.

b. Cleaning and Inspection

WARNING

Clean all parts in a well-ventilated area. Avoid inhalation of solvent fumes and prolonged exposure of the skin to cleaning solvent. Wash exposed skin thoroughly.

(1) Discard and replace the gasket (7, fig. 4-20). Clean all remaining parts with cleaning solvent (fed. spat. P-D-680); dry thoroughly.

(2) Inspect the cover (6) and body (16) for cracks, distortion, damaged threads, and damaged flanges.

(3) Inspect the float (9) for cracks, distortion,

and leaking. The presence of any fluid in the float indicates leaking; you must replace the float.

(4) Inspect the valve (11) for wear or grooves in the seating surfaces. If either the valve or valve seat (14) is damaged, you must replace both parts.

(5) Inspect the float lever (15), pin (12), and retainer (10) for wear and distortion.

(6) *Replace any defective parts.*

c. Reassembly and Installation. Reassemble and install the air eliminator as shown in figures 4-20 and 4-17. After installation, start the pump and check that the assembly discharges the air from the discharge system but that it does not allow the escape of a significant amount of fluid through the valve at the top of the assembly.

APPENDIX A

REFERENCES

A-1 Fire Protection

TB 5-4200-200-10

Hand Portable Fire Extinguishers for Army Users

A-2 Lubrication

C9100IL

LO 5-4320-272-12

Fuel, Lubricants, Oils and Waxes
Pumping Assembly and Engine
Lubrication Order

A-3 Painting

TM 9-913

Painting Instructions for Field Use

A-4 Radio Suppression

TM 11-483

Radio Interference Suppression

A-5 Maintenance

TM 9-1870-1

TM 5-4320-272-20P

TM 38-750

Care and Maintenance of Pneumatic Tires
Organizational Maintenance Repair Parts and
Special Tools List, Pumping Assembly
Army Equipment Record Procedures

A-6 Shipment and Storage

TM 740-90-1

Administrative Storage

A-7 Destruction to Prevent

Enemy Use

TM 750-244-3

Procedures for Destruction of Equipment to
Prevent Enemy Use

APPENDIX B

MAINTENANCE ALLOCATION CHART

Section I. INTRODUCTION

B-1. General

a. This section provides a general explanation of all maintenance and repair functions authorized at various maintenance levels.

b. Section II designates overall responsibility for the performance of maintenance functions on the identified end item or component. The implementation of the maintenance functions upon the identified end item or component will be consistent with the assigned maintenance functions.

c. Section III lists the special tools and test equipment required for each maintenance function as referenced from Section II.

d. Section IV contains supplemental instructions or explanatory notes required for a particular maintenance function.

B-2. Explanation of Columns in Section II

a. *Group Number, Column (1).* The assembly group number is a numerical group assigned to each assembly. The assembly groups are listed on the MAC in disassembly sequence beginning with the first assembly removed in a top down disassembly sequence.

b. *Assembly Group, Column (2).* This column contains a brief description of the components of each assembly group.

c. *Maintenance Functions, Column (3).* This column lists the various maintenance functions (A through K). The upper case letter placed in the appropriate column indicates the lowest maintenance level authorized to perform these functions. The active repair time required to perform the maintenance function is included directly below the symbol identifying the category of maintenance. The symbol designations for the various maintenance levels are as follows:

C—Operator or crew
O—Organizational maintenance
F—Direct support maintenance
H—General support maintenance
D—Depot maintenance

The maintenance functions are defined as follows:

A-Inspect. to determine serviceability of an item by comparing its physical, mechanical,

and electrical characteristics with established standards.

B-Test. to verify serviceability and to detect electrical or mechanical failure by use of test equipment.

C-Service. To clean, to preserve, to charge, and to add fuel, lubricants, cooling agents, and air. (If it is desired that elements, such as painting and lubricating, be defined separately, they may be so listed.)

D-Adjust. To rectify to the extent necessary to bring into proper operating range.

E-Align. To adjust specified variable elements of an item to bring to optimum performance.

F-Calibrate. To determine the corrections to be made in the readings of instruments or test equipment used in precise measurement. Consists of the comparison of two instruments, one of which is a certified standard of known accuracy, to detect and adjust any discrepancy in the accuracy of the instrument being compared with the certified standard.

G-Install. To set up for use in an operational environment such as an emplacement, site, or vehicle.

H-Replace. To replace unserviceable items with serviceable like items.

I-Repair. Those maintenance operations necessary to restore an item to serviceable condition through correction of material damage or a specific failure. Repair may be accomplished at each level of maintenance.

J-Overhaul. Normally, the highest degree of maintenance performed by the Army in order to minimize time work is in process consistent with quality and economy of operation. It consists of that maintenance necessary to restore an item to completely serviceable condition as prescribed by maintenance standards in technical publications for each item of equipment. Overhaul normally does not return an item to like new, zero mileage, or zero hour condition.

K-Rebuild. The highest degree of materiel maintenance. It consists of restoring equipment as nearly as possible to new condition in

accordance with original manufacturing standards. Rebuild is performed only when required by operational considerations or other paramount factors and then only at the depot maintenance level. Rebuild reduces to zero the hours or miles the equipment, or component thereof, has been in use.

d. Tools and Equipment, Column (4). This column is provided for referencing by code the special tools and test equipment (Sec. III), required to perform the maintenance functions (Sec. II).

e. Remarks, Column (5) This column is provided for referencing by code the remarks (Sec. IV) pertinent to the maintenance functions.

B-13. Explanation of Columns in Section III

a. Reference Code. This column consists of a number and a letter separated by a dash. The number references the T&TE requirements listed in Section II. The letter represents the specific

maintenance function the item is to be used with in column A through K of Section II.

b. Maintenance Level. This column shows the lowest level of maintenance authorized to use the special tool or test equipment.

c. Nomenclature. This column lists the name or identification of the tool or test equipment.

d. Tool Number. This column lists the manufacturer's code an part number, or Federal stock number of tool or test equipment.

B-4. Explanation of Columns in Section IV

a. Reference Code. This column consists of two letters separated by a dash (entered from col. 5 of Sec. II). The first letter references alpha sequence in Col. 5 and the second letter references a maintenance-function, Col. 3, A through K.

b. Remarks. This column lists information pertinent to the maintenance function to be performed (as indicated in Sec. II).

Section II. MAINTENANCE ALLOCATION CHART

(1) Group No.	(2) Functional group	(3) Maintenance functions											(4) Tools and equipment	(5) Remarks
		A	B	C	D	E	F	G	H	I	J	K		
		Inspect	Test	Service	Adjust	Align	Calibrate	Install	Replace	Repair	Overhaul	Rebuild		
01 ENGINE														
0100	Engine Assembly	G 0.1	O 1.0	C 1.0					F 8.0	F 16.0	H 80.0			A-B
0101	Crankcase, Block and Cylinder Head								F 4.0		H 10.0			B-H
0102	Crankshaft		H 2.0						H 4.0					
0103	Flywheel Assembly								F 2.0					
0104	Pistons, Connecting Rods								H 7.0					
0105	Valve, Camshafts and Timing System								H 6.0	F 8.0				C-I
0106	Lubricating System	C 0.1		C 1.0					H 2.5					D-C
0108	Manifolds, Intake and Exhaust	C 0.1							O 2.0					
03 FUEL SYSTEM														
0301	Carburetor	C 0.1			O 0.5				O 1.0					
0302	Fuel Pump	C 0.1							O 0.5					
0304	Air Cleaner	C 0.1		C					O 0.2					
0306	Tanks, Lines and Fittings	C 0.2		C 0.3					O 1.5					
0308	Governor and Controls	C 0.1			O 0.5				F 1.0					
0309	Fuel Filter	C 0.1		C 0.2					O 0.3					
0312	Throttle and Choke Controls	C 0.1			O 0.5				O 0.5					
04 EXHAUST SYSTEM														
0401	Muffler and Pipes	C 0.1							O 1.0					
05 COOLING SYSTEM														
0502	Cowling, Deflectors, Air Ducts, Shrouds, etc.	C 0.1							F 2.0	O 3.0				E-I
06 ELECTRICAL SYSTEM														
0601	Alternator	C 0.1	O 0.5						F 0.5	O 0.5				F-I
0602	Regulator	C 0.1	O 0.5						F 0.5					
0603	Starting Motor	C 0.1							O 0.5	O 0.5				G-I
0605	Ignition Components	C 0.2	O 0.5		O 0.5				O 0.5					H-I
0606	Engine Safety Controls	C 0.1	O 0.5		O 0.5				O 0.5					
0607	Control Panel	C 0.2							O 2.0					
0608	Miscellaneous Items	C 0.3							O 0.5					
0609	Lights	C 0.1							O 0.5					
0610	Sending Units and Warning Switches	C 0.1							O 0.5					
0612	Batteries, Storage	C 0.1	O 0.2	C 0.3					O 0.5					

Section II. MAINTENANCE ALLOCATION CHART

(1) Group No.	(2) Functional group	(3) Maintenance functions											(4) Tools and equipment	(5) Remarks					
		A	B	C	D	E	F	G	H	I	J	K							
		Inspect	Test	Service	Adjust	Align	Calibrate	Install	Replace	Repair	Overhaul	Rebuild							
0615	Radio Interference, Suppression	H	H	H
	10 AXLE	1.0	2.0	0.5
1000	Axle Assembly	C	F
	13 WHEELS	0.2	8.0
1311	Wheel Assembly	C	..	O	O	O
	1311	0.1	..	1.0	0.5	0.5
1313	Tires, Tubes	C	..	C	O	O
	1313	0.1	..	0.2	0.5	0.5
	15 FRAME
1501	Frame Assembly	C	H
	1501	0.2	8.0
1503	Pintles and Towing Attachments	C	..	C	O
	1503	0.1	..	0.1	0.5
	18 BODY, CAB, HOOD AND HULL
1808	Stowage Boxes	C	O
	1808	0.1	0.5
	22 ACCESSORY ITEMS
2202	Reflectors	C	O
	2202	0.1	0.2
2210	Data Plates	O	H
	2210	0.1	0.5
	47 GAGES, NON-ELECTRICAL
4701	Tachometer	C	O
	4701	0.1	0.3
4702	Gages, Pressure and Vacuum	C	H	O
	4702	0.1	1.0	0.3
	55 PUMPS
5500	Pump Assembly	C	H	F	H	H
	5500	0.1	16.0	8.0	12.0	24.0
5501	Shaft, Impeller, Seals and Bearings	C	F	H	I-H
	5501	0.1	4.0	8.0
5505	Suction and Discharge Assemblies	C	..	C	O
	5505	0.1	..	0.4	2.0

Section III. TOOL AND SPECIAL TEST EQUIPMENT REQUIREMENTS

Reference code	Maintenance Category	Nomenclature	Tool number
----------------	----------------------	--------------	-------------

No Special Tools or Test Equipment Required.

Section IV. REMARKS

Reference code	Remarks
A-B B-H C-I D-C E-I F-I, G-I H-I I-H	Compression Replace Cylinder Head Reface Valves Replace filter elements; drain & refill crankcase Straighten and Weld Replace Brushes Replace Breaker Points, Condensers, Coils etc., no major repairs required. Replace Seals

INDEX

	Paragraph	Page		Paragraph	Page			
A								
Accessory items:								
Cleaning	4-39 b	4-32	Inspection	4-44 c	4-39			
Description	4-38	4-31	Installation	4-44 d	4-39			
Inspection	4-39 b	4-32	Reassembly	4-44 b	4-39			
Reassembly	4-39 c	4-33	Removal	4-44 b	4-39			
Removal	4-39 a	4-31	Cleaning (See specific items)					
Adjustment (See specific items)			Cold, operation in extreme	2-6	2-5			
Administrative storage	1-6	1-1	Compression, engine, checking	4-34	4-29			
Air cleaner and piping:			Control panel:					
Cleaning	4-17 b	4-8	Cleaning	4-28 b	4-27			
Description	4-16 a	4-6	Description	2-4,4-22 g	2-1,4-16			
Disassembly	4-17 a	4-7	Disassembly	4-28 a	4-25			
Inspection	4-17 b	4-8	Inspection	4-28 b	4-27			
Installation	4-17 c	4-9	Installation	4-28 c	4-27			
Reassembly	4-17 c	4-9	Reassembly	4-28 c	4-27			
Removal	4-17 a	4-7	Removal	4-28 a	4-25			
Servicing	3-9 b	3-7	D					
Air Eliminator:			Data, tabulated	1-9	1-4			
Cleaning	4-45 b	4-40	Description (See specific items)					
Description	4-40 e	4-33	Destruction of Army materiel to					
Disassembly	4-45 a	4-39	prevent enemy use	1-5	1-1			
Inspection	4-45 b	4-40	Differences in models	1-8	1-4			
Installation	4-45 c	4-40	Disassembly (See specific items)					
Reassembly	4-45 c	4-40	Discharge gages, lines, and fittings:					
Removal	4-45 a	4-39	Cleaning	4-30 b	4-28			
Alternator:			Disassembly	4-30 a	4-28			
Description	4-22 b	4-15	Inspection	4-30 b	4-28			
Testing	4-24	4-18	Installation	4-30 c	4-28			
B								
Battery, battery box, and leads:			Reassembly	4-30 c	4-28			
Cleaning	4-23 c	4-17	Removal	4-30 a	4-28			
Description	4-22 a	4-15	Discharge piping:					
Disassembly	4-23 b	4-16	Cleaning	4-26 b	4-37			
Inspection	4-23 d	4-18	Description	4-40 b	4-33			
Installation			Disassembly	4-42 a	4-35			
Reassembly	4-23 d	4-18	Inspection	4-42 b	4-37			
Removal	4-23 b	4-16	Installation	4-42 c	4-37			
Service	4-23 a	4-16	Reassembly	4-42 c	4-37			
Removal	4-23 b	4-16	Removal	4-42 a	4-35			
Breaker point assembly:			Dismantling for movement	4-3	4-2			
Adjusting	4-25 b	4-19	E					
Replacing	4-25 b	4-19	Electrical system, maintenance	3-10	3-8			
C								
Carburetor:			Enemy use, destruction of Army					
Adjustment	4-20 a	4-12	materiel to prevent	1-5	1-1			
Cleaning	4-20 c	4-14	Engine:					
Description	4-16 e	4-7	Checking compression	4-34	4-29			
Inspection	4-20 c	4-14	Control panel	4-28	4-25			
Installation	4-20 d	4-14	Description	4-32	4-28			
Removal	4-20 b	4-13	Lubrication	3-3	3-1			
Chart, troubleshooting, organizational			Maintenance	3-8	3-5			
maintenance	4-13	4-4	Oil change	3-8 a	3-5			
Checking:			Oil filter replacement	3-8 b	3-5			
Engine compression	4-34	4-29	Equipment:					
Magneto spark	4-25 a	4-19	Inspecting	4-1	4-1			
Cheeks and services, preventive			Serviceability criteria	1-4	1-1			
maintenance	3-5,4-11	3-2,4-3	Servicing	4-1	4-1			
Check valve:			Errors, reporting of	1-3	1-1			
Adjustment	4-44 a	4-38	Exhaust manifold:					
Cleaning	4-44 c	4-39	Cleaning	4-33 b	4-28			
Description	4-40 d	4-33	Inspection	4-33 b	4-28			
Disassembly	4-44 b	4-39	Installation	4-33 c	4-29			
			Reassembly	4-33 c	4-29			
			Removal	4-33 a	4-28			
			Exhaust system	4-14	4-6			

	Paragraph		Paragraph	Page
F				
Forms and records, maintenance	1-2	1-1		
Fuel pump:				
Cleaning	4-19 c	4-12		
Description	4-16 c	4-7		
Disassembly	4-19 b	4-11		
Inspection	4-19 c	4-12		
Installation	4-19 d	4-12		
Reassembly	4-19 d	4-12		
Removal	4-19 b	4-11		
Testing	4-19 a	4-11		
Fuel strainer:				
Cleaning	4-19 c	4-12		
Description	4-16 d	4-7		
Inspection	4-19 c	4-12		
Installation	4-19 d	4-12		
Reassembly	4-19 d	4-12		
Removal	4-19 b	4-11		
Servicing	3-9 c	3-7		
Testing	4-19 a	4-11		
Fuel system:				
Air cleaner service	3-9 b	3-7		
Description	4-16	4-6		
Maintenance	3-9	3-6		
Fuel tank, lines, and fittings:				
Cleaning	4-18 b	4-11		
Description	4-16 b	4-7		
Disassembly	4-18 a	4-9		
Inspection	4-18 b	4-11		
Installation	4-18 c	4-11		
Reassembly	4-18 c	4-11		
Removal	4-18 a	4-9		
Servicing	3-9 b	3-7		
G				
Gages:				
Discharge	4-30	4-28		
Non-electrical	4-29	4-27		
Suction	4-30	4-28		
Vacuum	4-30	4-28		
Gate valve:				
Cleaning	4-43 b	4-38		
Description	4-40 c	4-33		
Disassembly	4-43 a	4-37		
Inspection	4-43 b	4-38		
Installation	4-43 c	4-38		
Reassembly	4-43 c	4-38		
Removal	4-43 a	4-37		
Governor:				
Adjustment	4-21	4-15		
Description	4-16 f	4-7		
H				
Heat, operation in extreme	2-7	2-5		
High altitudes, operation in	2-8	2-5		
I				
Inspection (<i>See specific items</i>)				
Installation (<i>See specific items</i>)				
Instruments, controls and	2-2	2-1		
Intake manifold:				
Cleaning	4-33 b	4-28		
Inspection	4-33 b	4-28		
Installation	4-33 c	4-29		
Reassembly	4-33 c	4-29		
Removal	4-33 a	4-28		
L				
Lines and fittings, discharge, vacuum and suction	4-30	4-28		
Lubrication:				
Detailed information	3-2	3-1		
Engine	3-3	3-1		
Trailer	4-9	4-2		
M				
Magneto:				
Adjusting breaker point assembly	4-25 b	4-19		
Checking spark	4-25 a	4-19		
Cleaning	4-25 e	4-21		
Description	4-22 c	4-15		
Disassembly	4-25 d	4-21		
Inspection	4-25 e	4-21		
Installation	4-25 g	4-21		
Reassembly	4-25 f	4-21		
Removal	4-25 c	4-21		
Replacing breaker point assembly	4-25 b	4-19		
Switch	4-22 i	4-16		
Timing	4-25 g	4-21		
Maintenance (<i>See specific items</i>)				
Models, differences in	1-8	1-4		
Movement:				
Dismantling for	4-3	4-2		
Reinstallation after	4-4	4-2		
Muffler and piping:				
Cleaning	4-15 b	4-6		
Disassembly	4-15 a	4-6		
Inspection	4-15 b	4-6		
Installation	4-15 c	4-6		
Reassembly	4-15 c	4-6		
Removal	4-15 a	4-6		
N				
Non-electrical gages description	4-29 a	4-27		
O				
Oil:				
Engine, changing	3-8 a	3-5		
Filter, replacing	3-8 b	3-5		
Preamre safety switch	4-22 f	4-15		
Operation (<i>See specific items</i>)				
Operator / crew maintenance troubleshooting	3-7	3-3		
Organization maintenance trouble- shooting chart	4-13	4-4		
P				
Parts, maintenance repair	4-7	4-2		
Piping:				
Air cleaner	4-17	4-7		
Discharge	4-40 b, 4-42	4-33, 4-35		
Muffler	4-15	4-6		
Suction	4-41	4-33		
Preventive maintenance checks- and services	3-5, 4-11	3-2, 4-3		
Pump, description	4-40	4-33		
Pump, fuel:				
Cleaning	4-19 c	4-12		
Description	4-16 c	4-7		
Disassembly	4-19 b	4-11		
Inspection	4-19 c	4-12		
Installation	4-19 d	4-12		
Reassembly	4-19 d	4-12		

	Paragraph	Page		Paragraph	Page
Removal	4-19 <i>b</i>	4-11	Inspection	4-30 <i>b</i>	4-28
Testing	4-19 <i>a</i>	4-11	Installation	4-30 <i>c</i>	4-28
R			Reassembly	4-30c	4-28
Rain or humid conditions, operation			Removal	4-30 <i>a</i>	4-28
under	2-10	2-5	Suction piping and strainer:		
Reassembly (See <i>specific items</i>)			Cleaning	4-41 <i>b</i>	4-34
Records, maintenance forms and	1-2	1-1	Description	4-40 <i>a</i>	4-33
Regulator:			Disassembly	4-41 <i>a</i>	4-33
Description	4-22 <i>b</i>	4-15	Inspection	4-41 <i>b</i>	4-34
Testing	4-24	4-18	Installation	4-41 <i>c</i>	4-35
Reinstallation after movement	4-4	4-2	Reassembly	4-41 <i>c</i>	4-35
Removal (See <i>specific items</i>)			Removal	4-41 <i>a</i>	4-33
Repair parts, maintenance	4-7	4-2	Servicing	3-12	3-8
Replacing:			T		
Breaker point assembly	4-25 <i>b</i>	4-19	Tabulated data	1-9	1-4
Oil filter	3-8 <i>b</i>	3-5	Tachometer-hourmeter and tachometer		
Starter brush	4-27 <i>c</i>	4-24	drive:		
Reporting of errors	1-3	1-1	Cleaning	4-31 <i>b</i>	4-28
S			Inspection	4-31 <i>b</i>	4-28
Salt water areas, operation in	2-11	2-5	Installation	4-31 <i>c</i>	4-28
Sandy or dusty areas, operation in	2-9	2-5	Removal	4-31 <i>a</i>	4-28
Scope	1-1	1-1	Testing, fuel pump and strainer	4-19 <i>a</i>	4-11
Serviceability criteria, equipment	1-4	1-1	Timing, magneto.	4-25g	4-21
Service(s):			Tires and tubes:		
Battery	4-23 <i>a</i>	4-16	Cleaning	4-36 <i>b</i>	4-30
Preventive maintenance checks and .	3-5,4-11	3-2,4-3	Inspection	4-36 <i>b</i>	4-30
Servicing (See <i>specific items</i>)			Installation	4-36 <i>c</i>	4-30
Spark plugs:			Removal	4-36 <i>a</i>	4-29
Cleaning	4-26 <i>b</i>	4-23	Tools and equipment	4-5	4-2
Description	4-22 <i>d</i>	4-15	Trailer lubrication.	4-9	4-2
Inspection	4-26 <i>b</i>	4-23	Troubleshooting:		
Installation	4-26 <i>c</i>	4-23	Chart, organizational maintenance	4-13	4-4
Removal	4-26 <i>a</i>	4-23	Operator/crew maintenance	3-7	2-3
Special tools and equipment	4-6	4-2	V		
Starter brush replacement	4-27 <i>c</i>	4-24	Vacuum gages, lines, and fittings:		
Starter switch description	4-22 <i>h</i>	4-16	Cleaning	4-30 <i>b</i>	4-28
Starting	2-3	2-4	Disassembly	4-30 <i>a</i>	4-28
Starting motor:			Inspection	4-30 <i>b</i>	4-28
Brush replacement.	4-27 <i>c</i>	4-24	Installation	4-30 <i>c</i>	4-28
Cleaning	4-27 <i>b</i>	4-24	Reassembly	4-30 <i>c</i>	4-28
Description	4-22 <i>e</i>	4-15	Removal	4-30 <i>a</i>	4-28
Inspection	4-27 <i>b</i>	4-24	W		
Removal	4-27a	4-23	Wheel and hub assembly:		
Stopping	2-5	2-5	Cleaning	4-37 <i>b</i>	4-31
Storage, administrative	1-6	1-1	Description	4-35	4-29
Strainer:			Dissassembly.	4-37 <i>a</i>	4-30
Fuel	39 <i>c</i> , 4-16 <i>d</i> ,	3-7,4-7,	Inspection	4-37 <i>b</i>	4-31
Suction	4-40 <i>a</i> 4-41	4-33	Installation	4-37 <i>c</i>	4-31
Suction gages, lines, and fittings:			Maintenance	3-11	3 - 8
Cleaning	4-30 <i>b</i>	4-28	Reassembly	4-37 <i>c</i>	4-30
Disassembly	4-30 <i>a</i>	4-28	Removal	4-37 <i>a</i>	4-30

By Order of the Secretary of the Army:

CREIGHTON W. ABRAMS
General, United States Army
Chief of Staff

Official:

VERNE L. BOWERS
Major General, United States Army
The Adjutant General

DISTRIBUTION:

To be distributed in accordance with DA Form 12-25A (qty rqr block no. 153)
Operator's Maintenance requirements for Petroleum Distribution.

☆ U.S. GOVERNMENT PRINTING OFFICE : 1988 O - 201-421 (71440)

